

HINGE DOOR & INLINE PANEL & SIDE PANEL

PORTE PIVOTANTE & PANNEAU EN ALIGNMENT & PANNEAULATÉRAL
SCHARNIER-TÜR & INLINE PANEL & SEITENPANELS
SCHARNIERDEUR & INLINE PANEEL & ZIJPANEEL

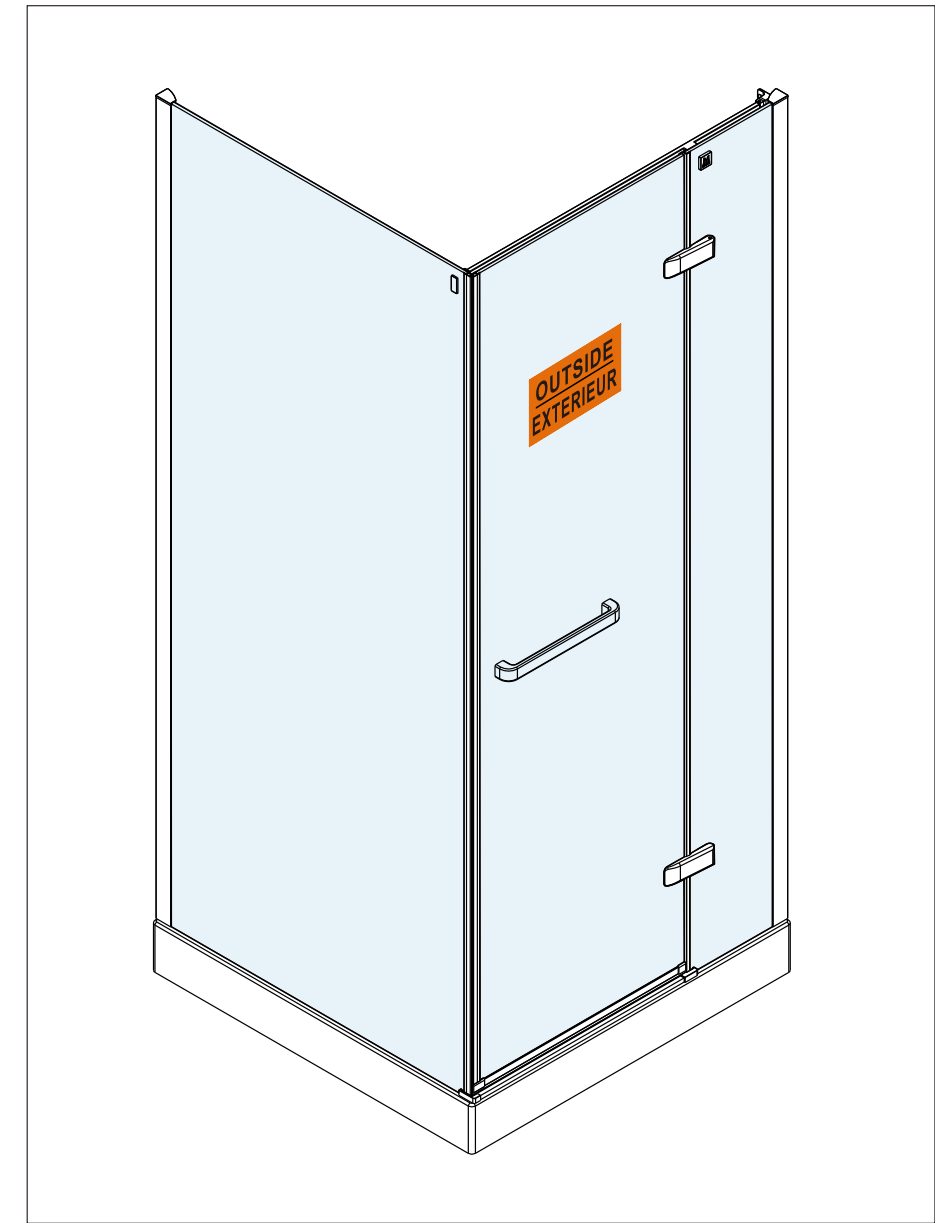

INSTALLATION GUIDE

Guide d'installation installationsanleitung installatiehandleiding

ENGLISH

If you install the product in a way that differs from this manual this will void all guarantees. Before installation check that the product meets all your requirements and is not damaged. By proceeding with installation, you accept the condition of the product. The wall plugs supplied with the installation kit are for use in solid walls. Hollow or 'stud partition' walls will require alternative fixings. Please consult your local hardware supplier for the correct type.

FRANCAIS

Si vous installez le produit d'une manière différente de celle présentée dans ce manuel toutes les garanties seront invalidées. Contrôlez avant le placement si le produit répond à toutes vos exigences et n'est pas endommagé. En procédant au placement, vous acceptez l'état dans lequel se trouve le produit. Les fixations murales fournies avec le kit d'installation sont prévues pour des murs en dur. En cas de mur creux, vous devrez consulter votre magasin de bricolage afin d'utiliser un modèle adéquat.

NEDERLANDS

Indien u het product plaatst op een manier die afwijkt van deze handleiding vervalt alle garantie. Controleer voor plaatsing of het product aan al uw eisen voldoet en niet beschadigd is. Indien u overgaat tot plaatsing, aanvaardt u de staat waarin het product zich bevindt. De met de installatie kit meegeleverde pluggen zijn voor gebruik in massieve muren. Niet-massieve muren vereisen alternatieve bevestigingen. Raadpleeg uw lokale bouwmarkt voor het juiste type.

DEUTSCH

Wenn Sie das Produkt nicht genau nach den Angaben in dieser Montageanleitung einbauen, verfällt die Garantie. Überprüfen Sie vor dem Einbau des Produkts, ob sämtliche Voraussetzungen erfüllt sind und das Produkt nicht beschädigt ist. Sobald Sie mit der Montage beginnen, sehen Sie, in welchem Zustand sich das Produkt befindet. Die mit dem Installationskit mitgelieferten Dübel sind für den Einsatz in festen Wänden. Nicht-feste Wände erfordern alternative Befestigungen. Bitte fragen Sie Ihren lokalen Baumarkt für den richtigen Typ.

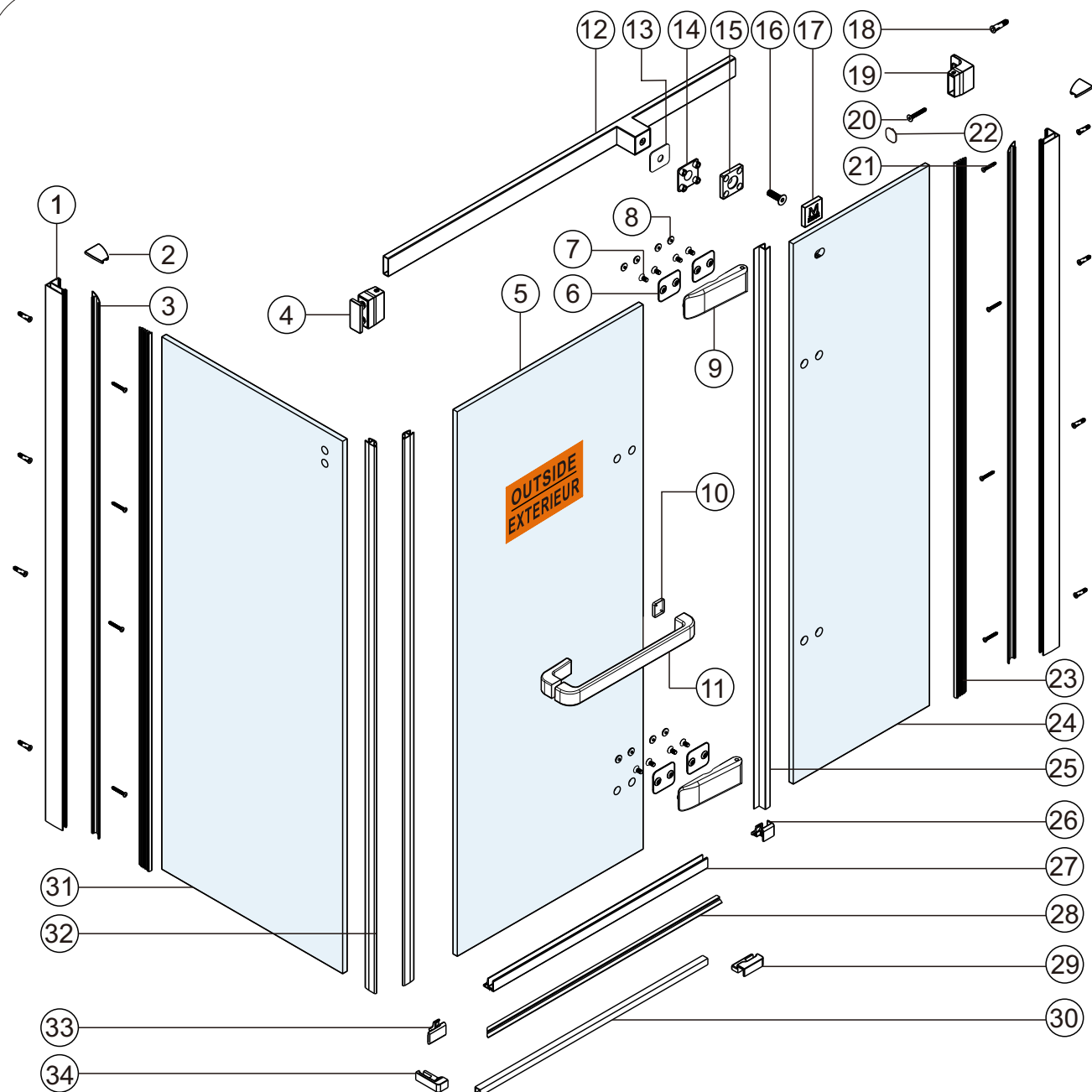

No.	Qty	Part No.	No.	Qty	Part No.	No.	Qty	Part No.
①	2	A01S0109	⑫	1	B	⑳	2	A01S0154
②	2	A01S0141	⑬	1	A06S0020	㉑	1	C
③	2	A01S0115	⑭	1	A06S0019	㉒	1	A06S0041
④	1	A06S0033	⑮	1	A06S0018	㉓	1	A06S0038
⑤	1	A	⑯	1	A06S0021	㉔	1	A06S0002
⑥	8	A06S0011	⑰	1	A06S0017	㉕	1	A06S0042
⑦	8	A06S0013	⑱	9	8SSJ066	㉖	1	A06S0036L/R
⑧	8	A06S0012	㉑	1	A06S0030/A06S0031	㉗	1	A06S0004
⑨	2	A06S0009	㉒	1	A06S0048	㉘	1	D
⑩	1	A06S0016	㉓	8	A06S0049	㉙	2	A06S0044
⑪	1	A06S0014	㉔	1	A06S0032	㉚	1	A06S0037L/R
						㉛	1	A06S0035 L/R

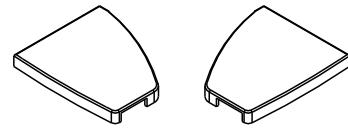
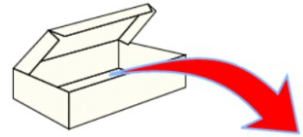

A01S0141 L/R
×2

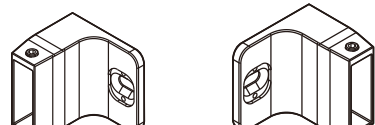

A06S0030 L
×1

A06S0031 R
×1

A06S0032
×1

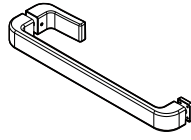

A06S0014
×1

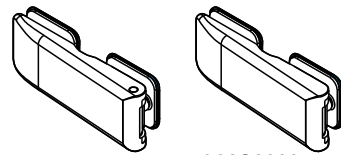

A06S0009
×1

A06S0009
×1

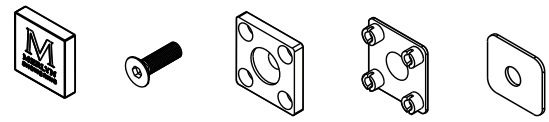

A06S0017
×1

A06S0021
×1

A06S0018
×1

A06S0019
×1

A06S0020
×1

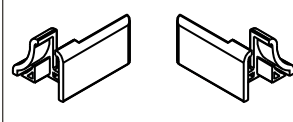

A06S0037 L/R
×1

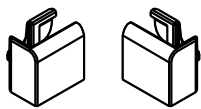

A06S0038 L/R
×1

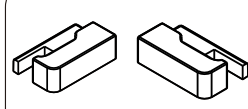

A06S0036 L/R
×1

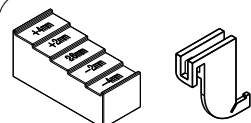

A06S0040
×2

A06S0039
×2

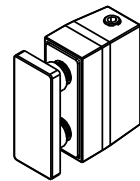

A06S0033
×1

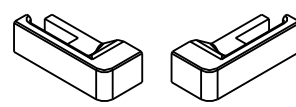

A01S0035 L/R
×1

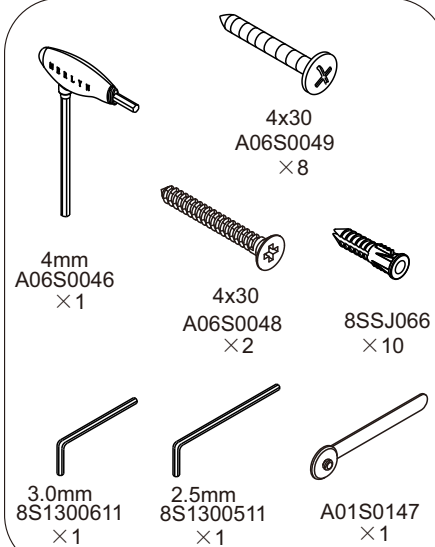

4mm
A06S0046
×1

4x30
A06S0048
×2

8SSJ066
×10

3.0mm
8S1300611
×1

2.5mm
8S1300511
×1

A01S0147
×1

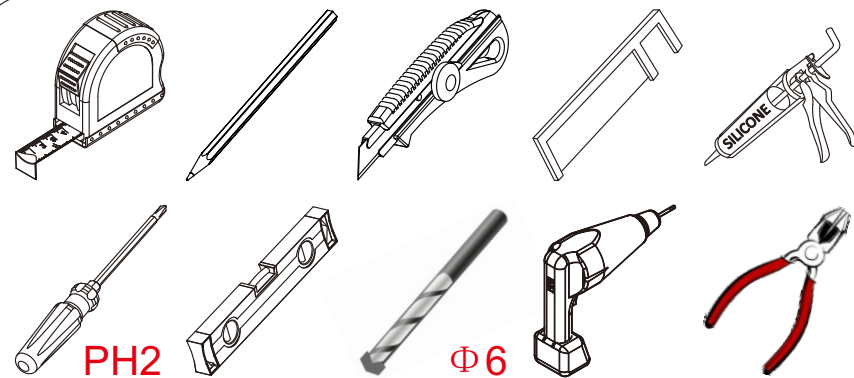

PH2

Φ6

1

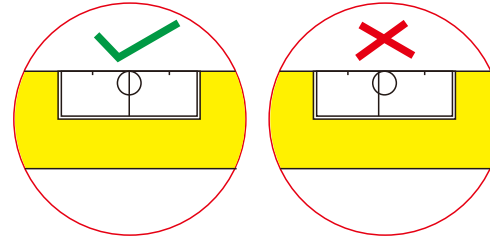

100%Level!

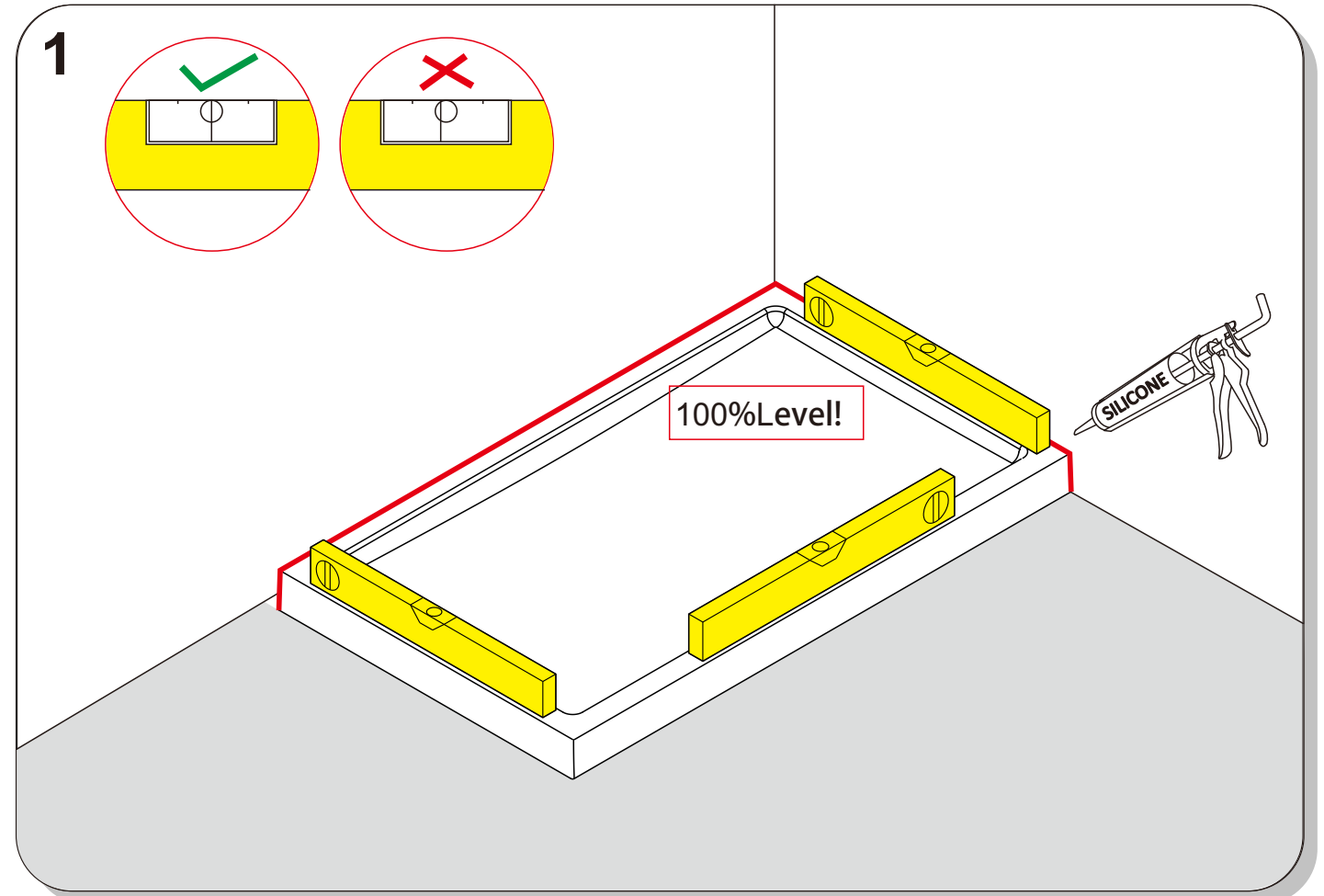

2

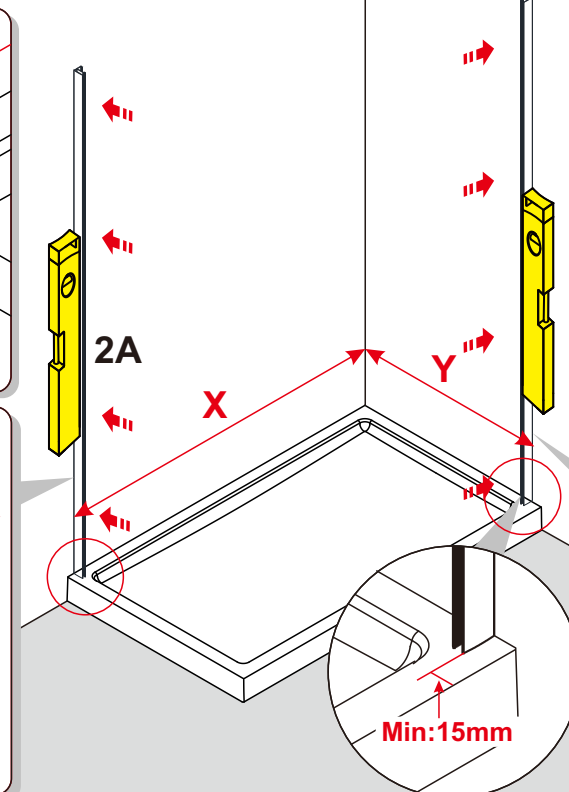
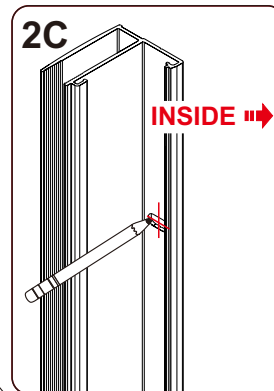
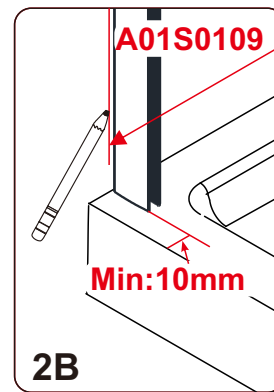

Size Taille Größe Maat	X
900+	865-890
1000+	965-990
1100+	1065-1090
1200+	1165-1190
1400+	1365-1390
1600+	1565-1590
1700+	1665-1690

Size Taille Größe Maat	Y
760	725-750
800	865-890
900	965-990

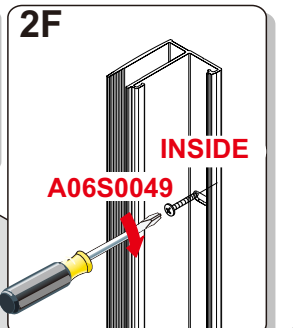
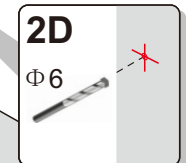

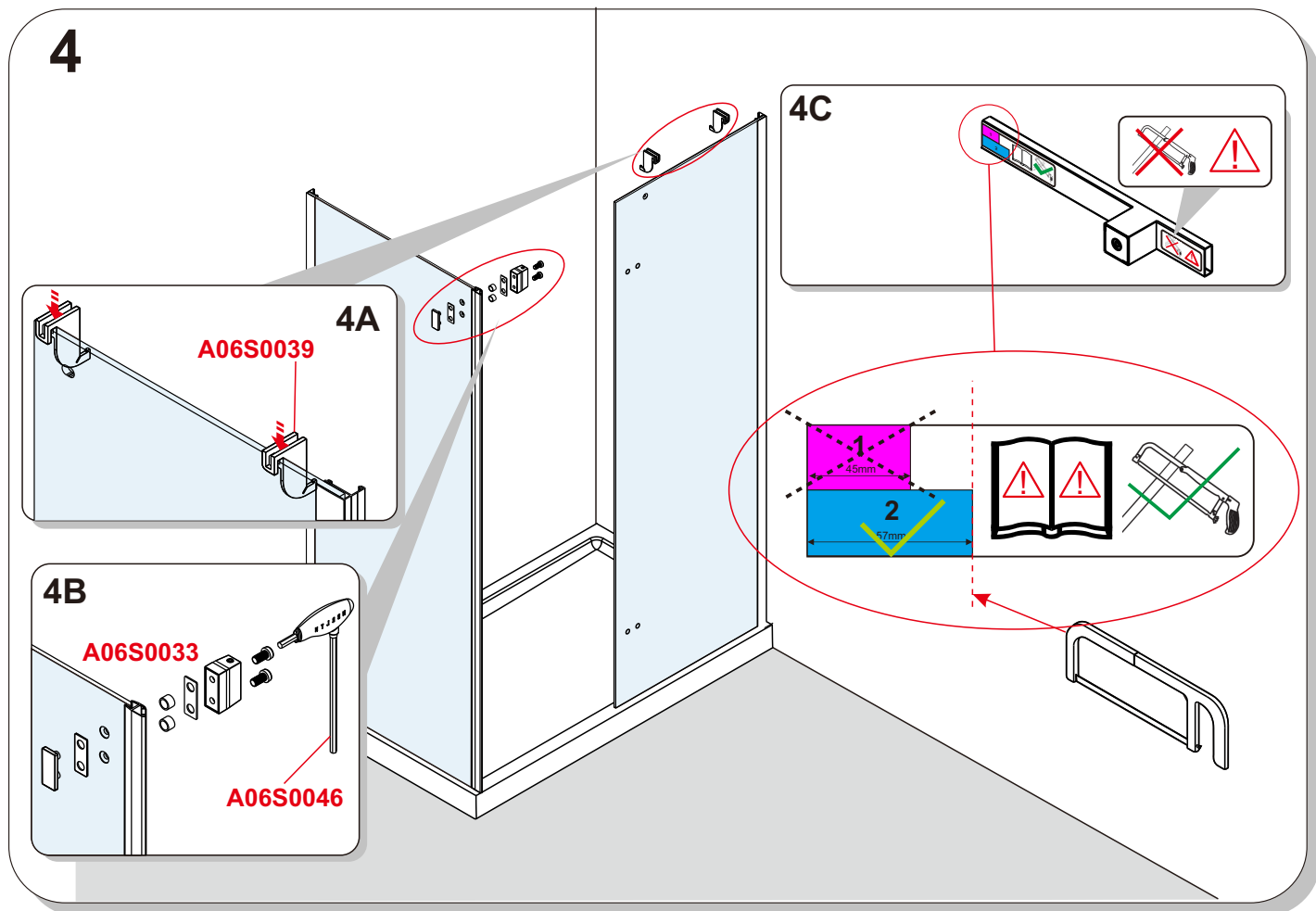
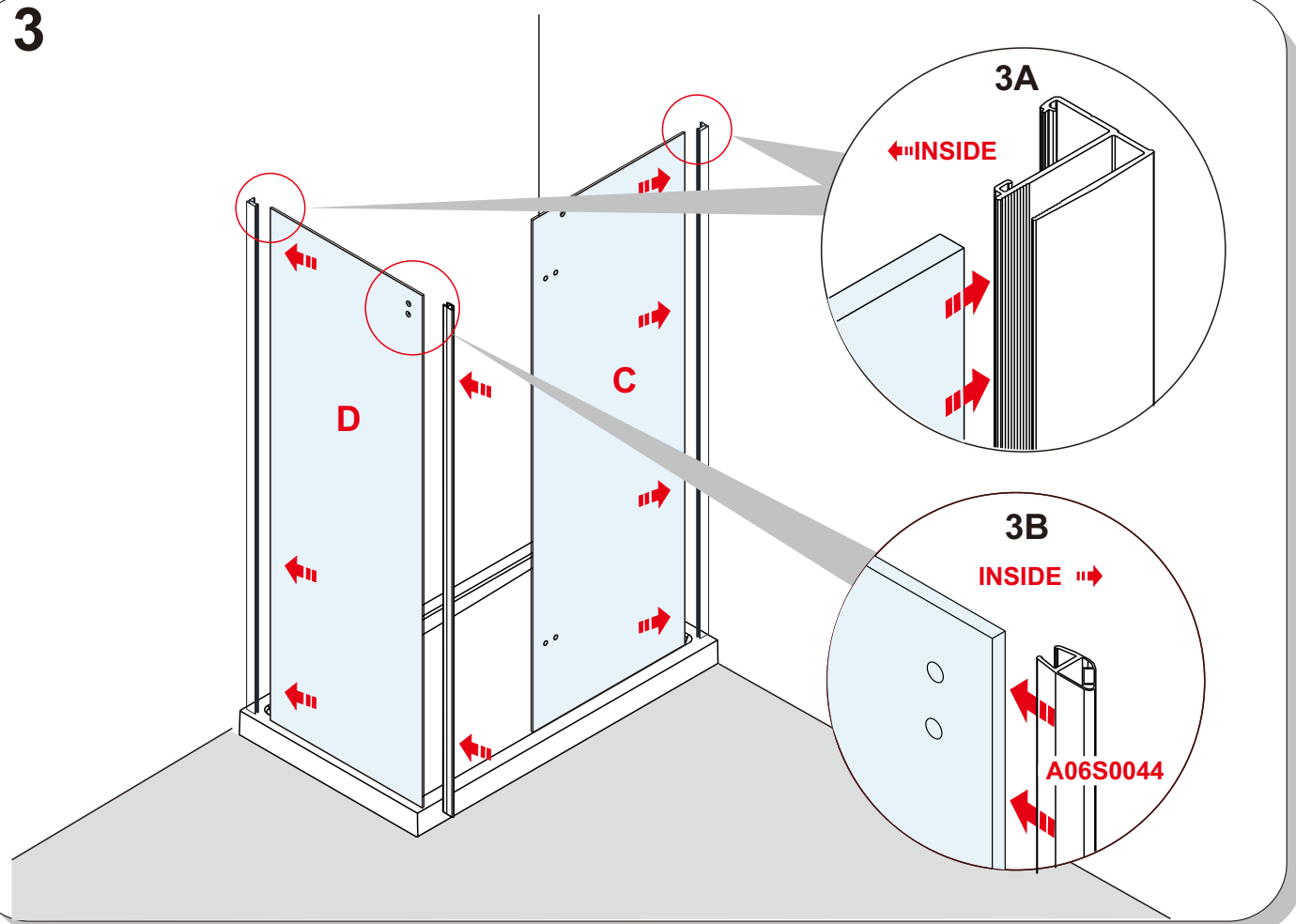

5.

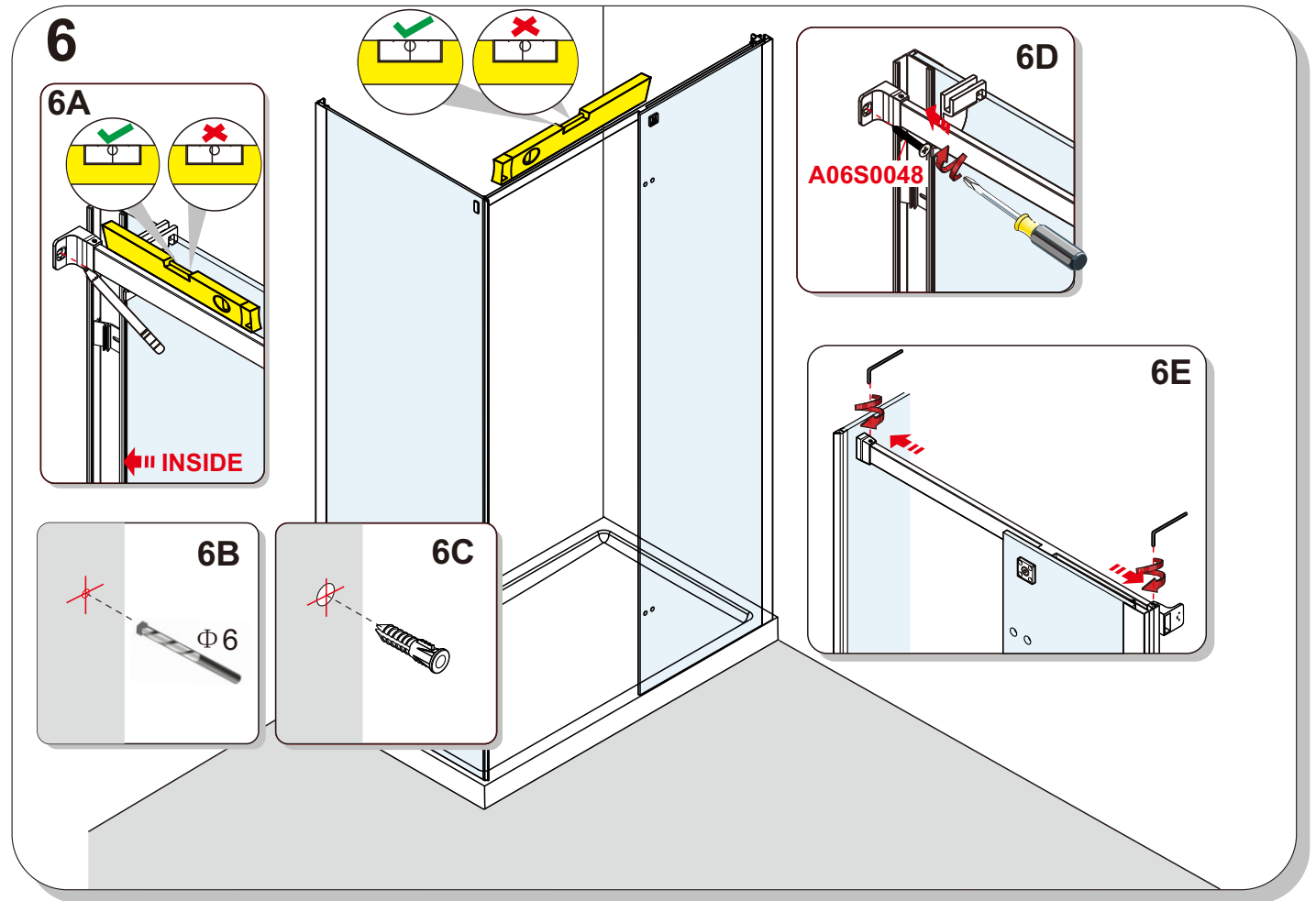
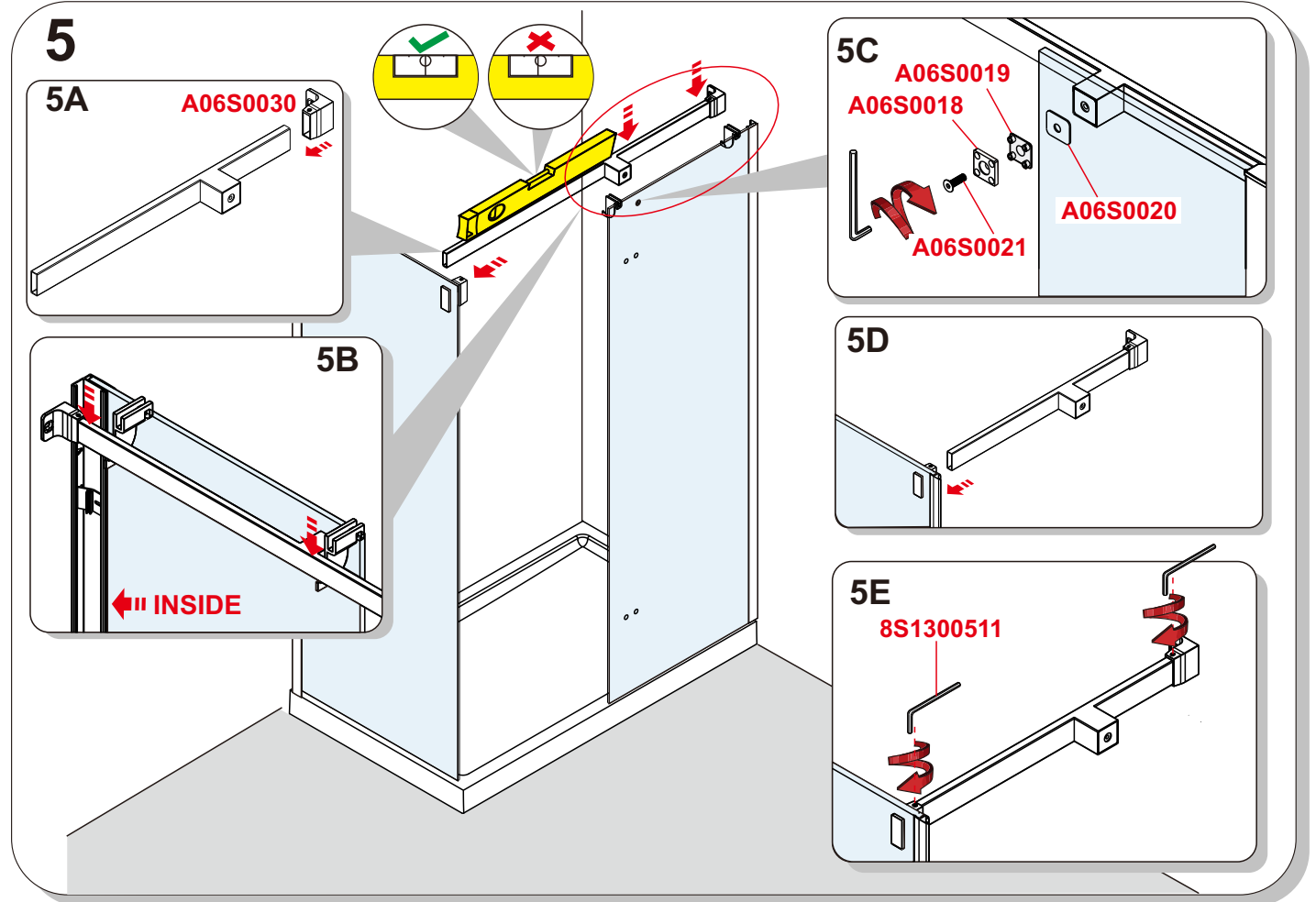

6.

7

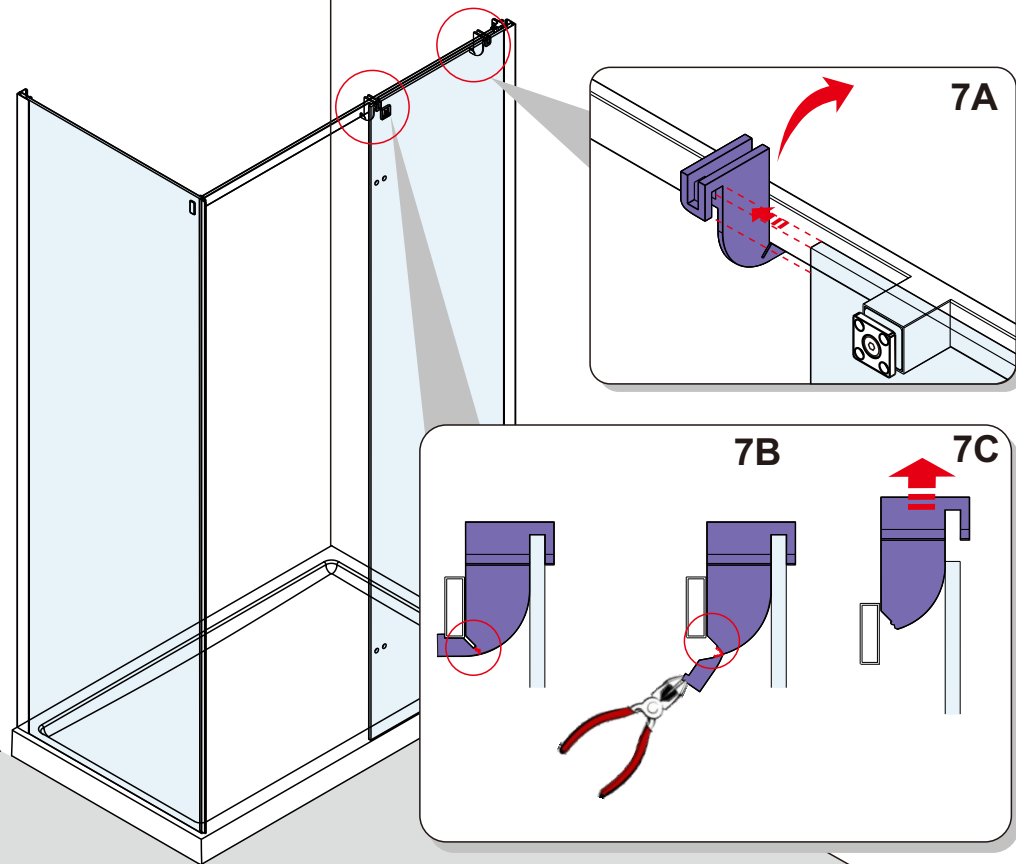

9

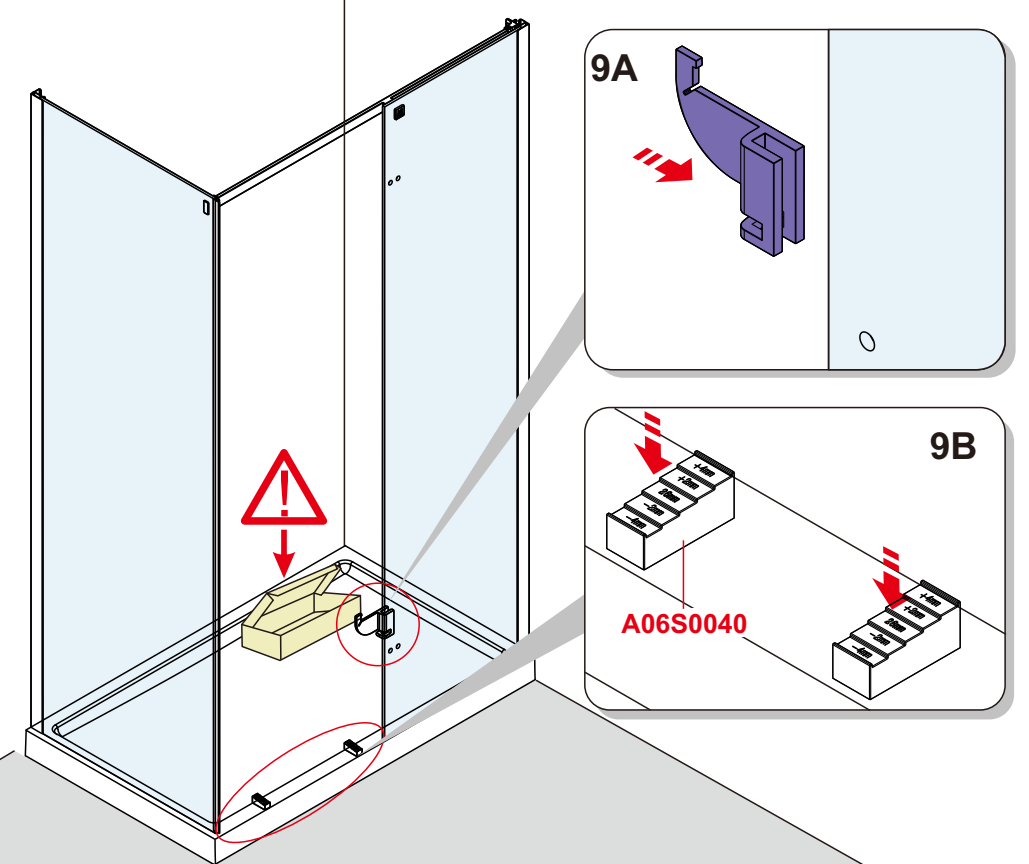

8

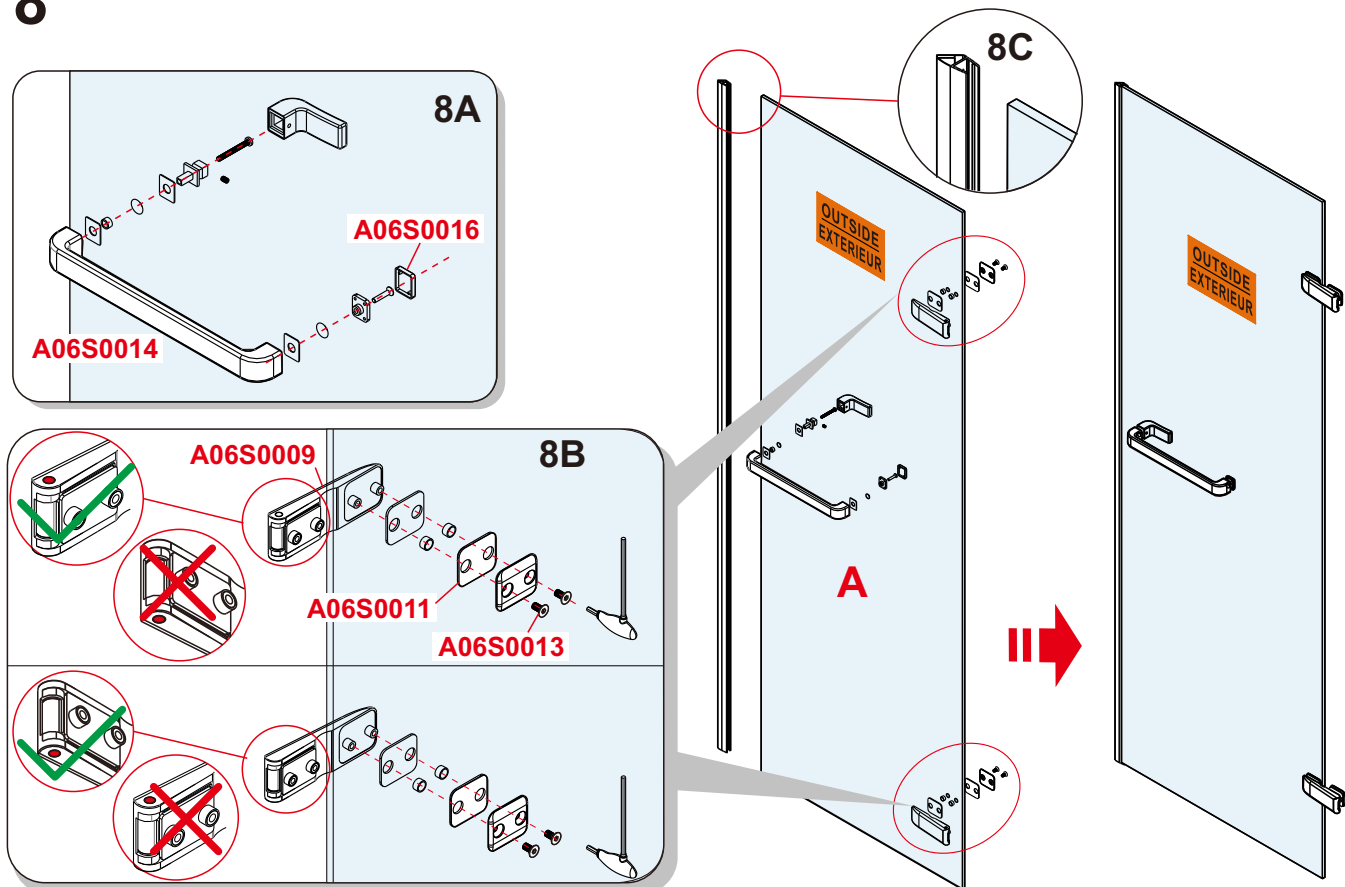

10

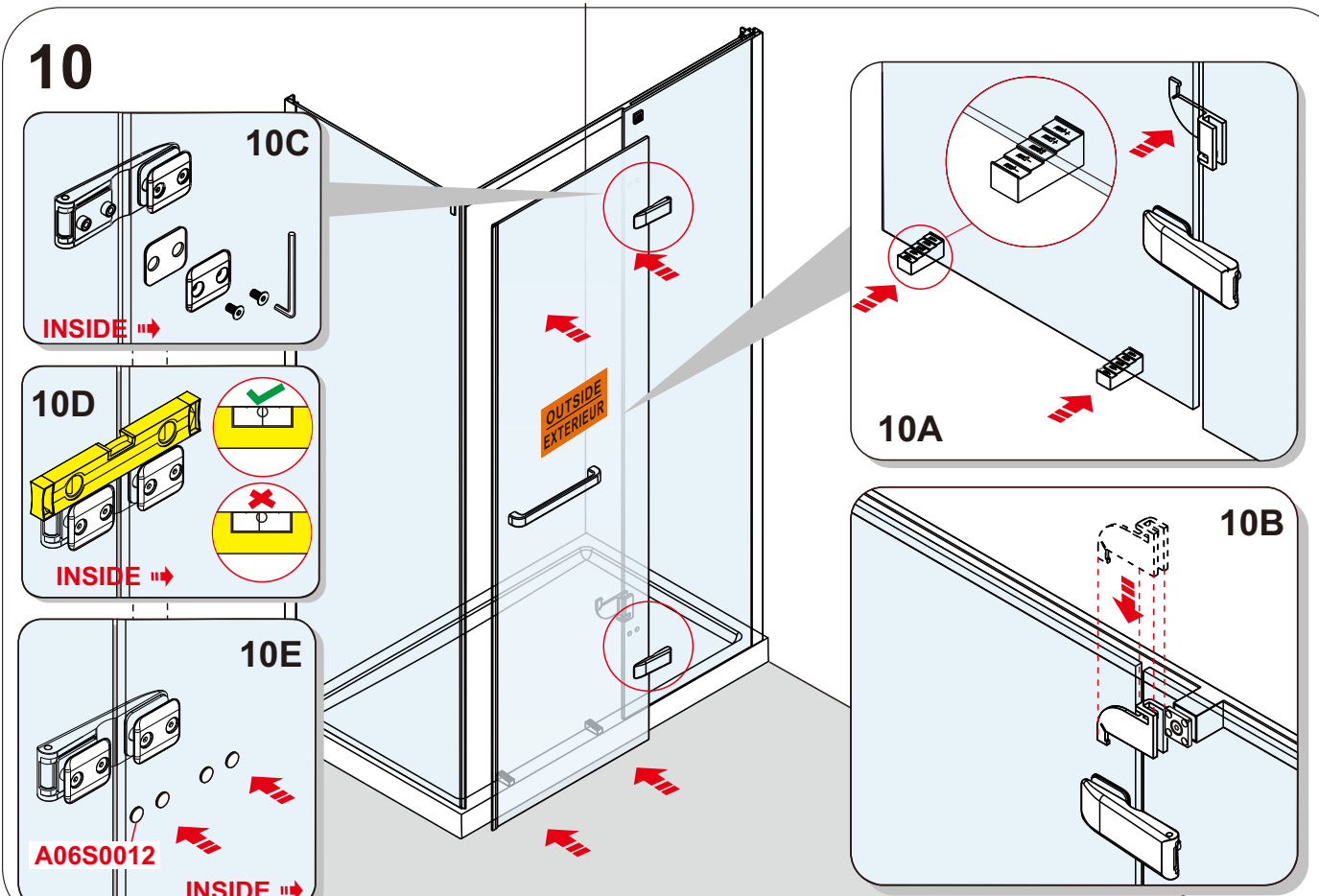

11

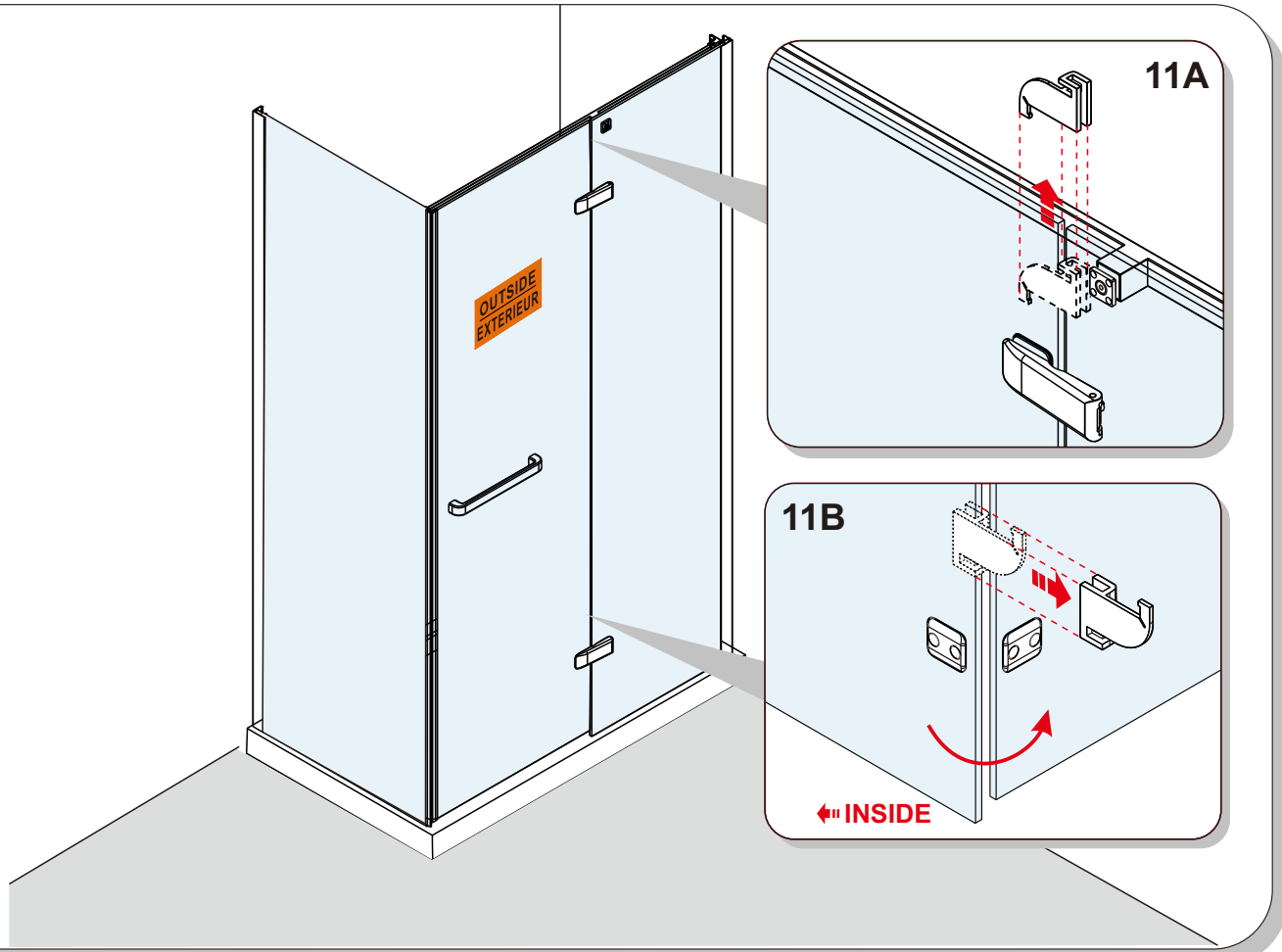

13

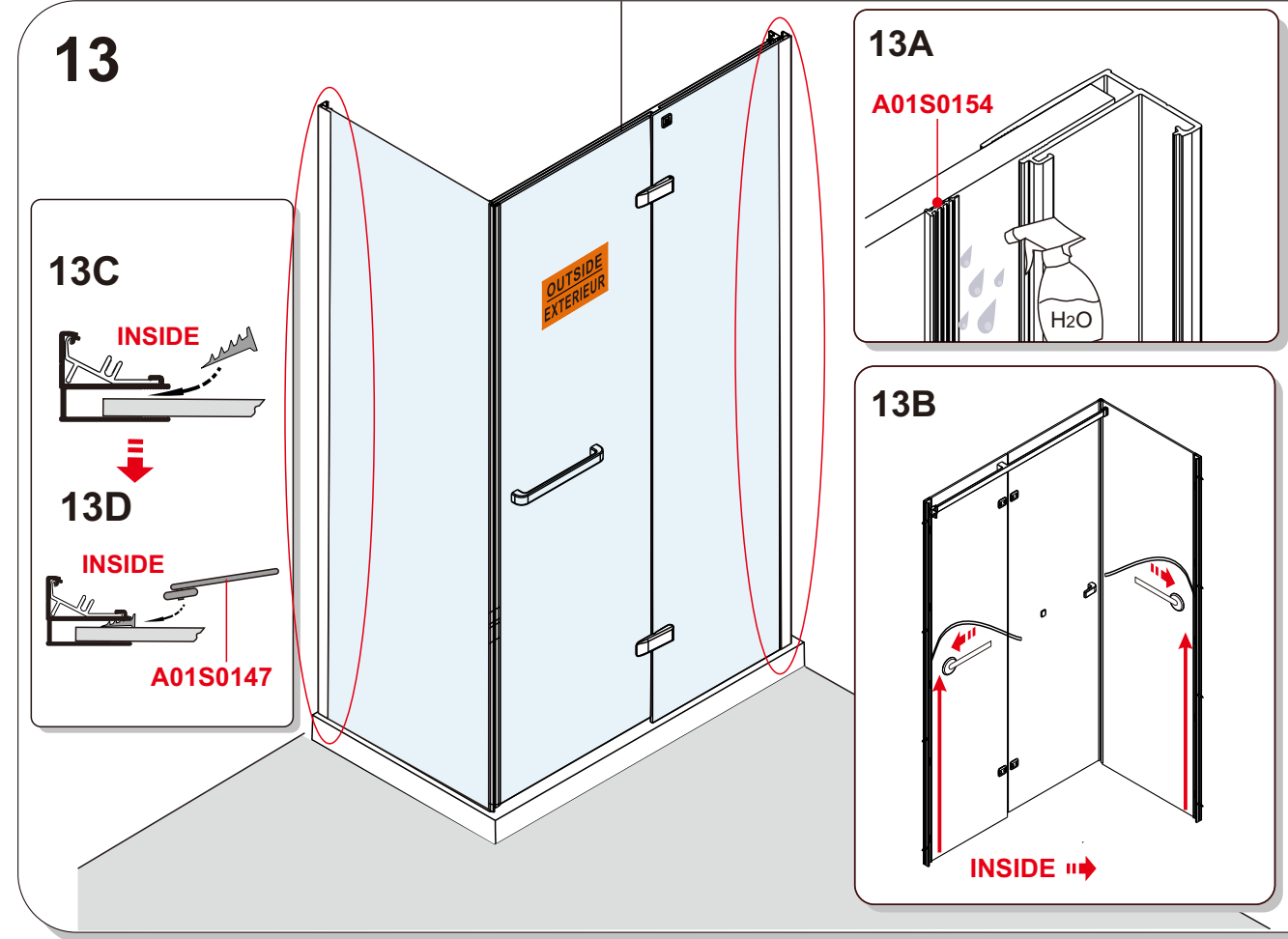

12

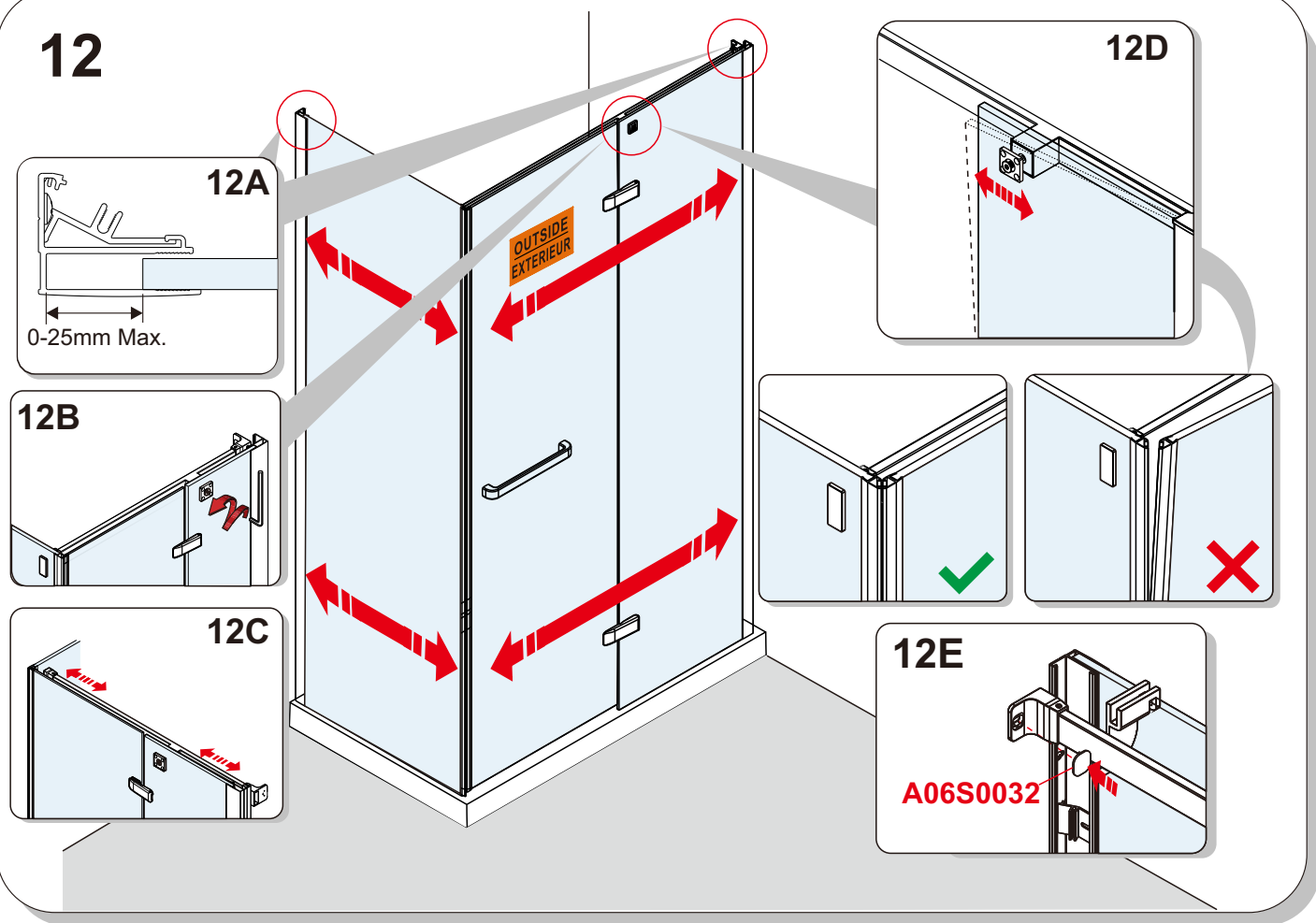

14

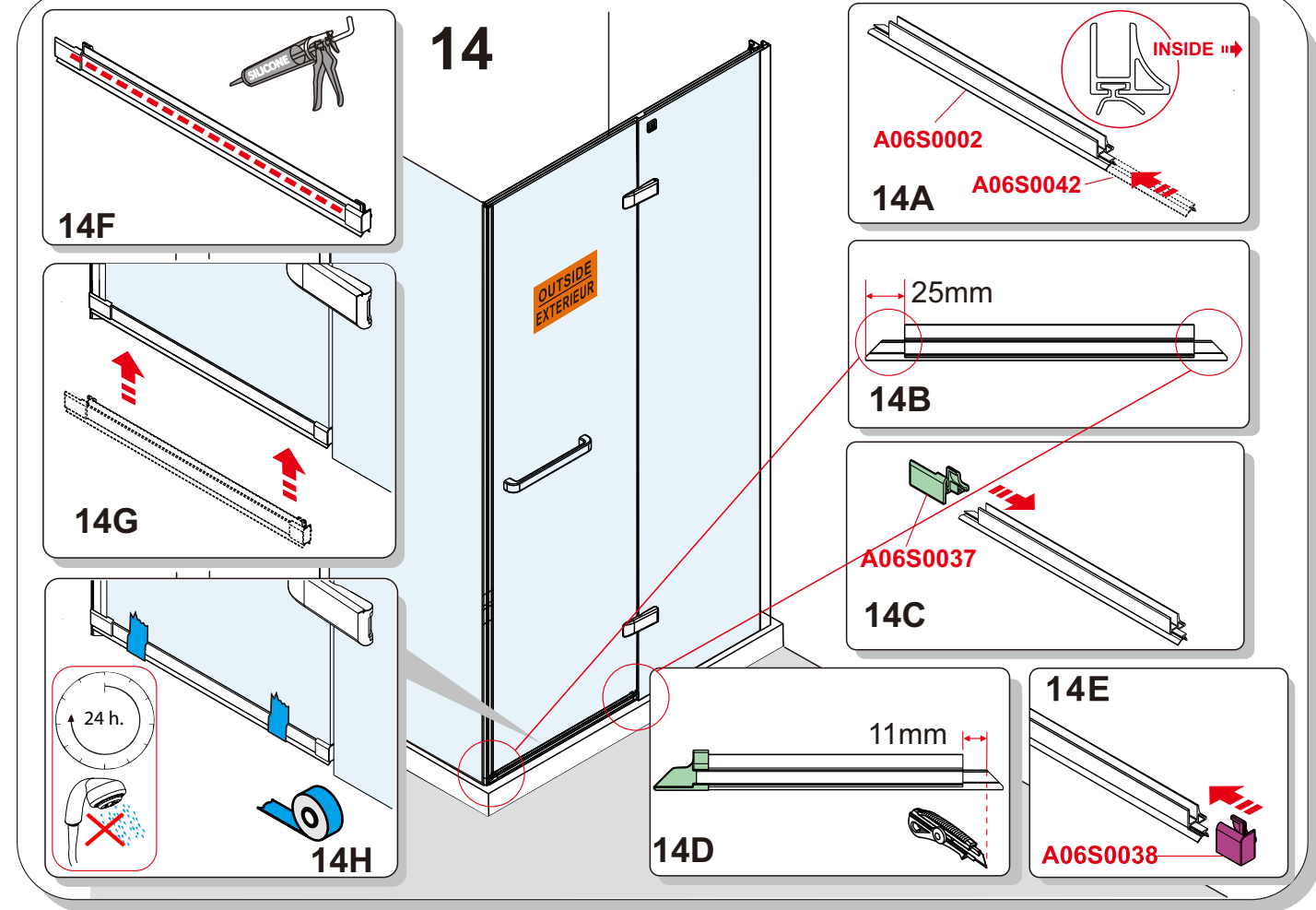

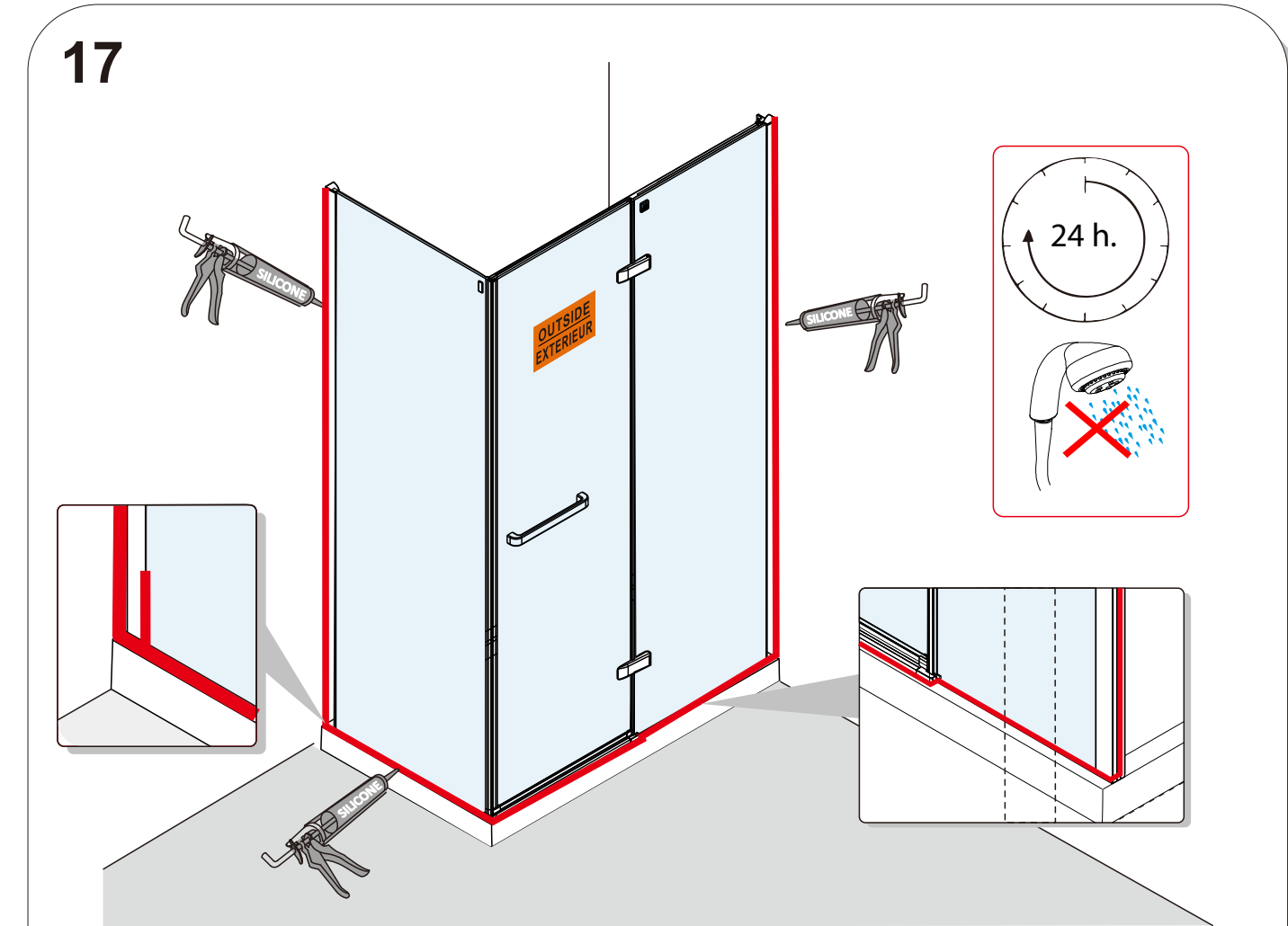
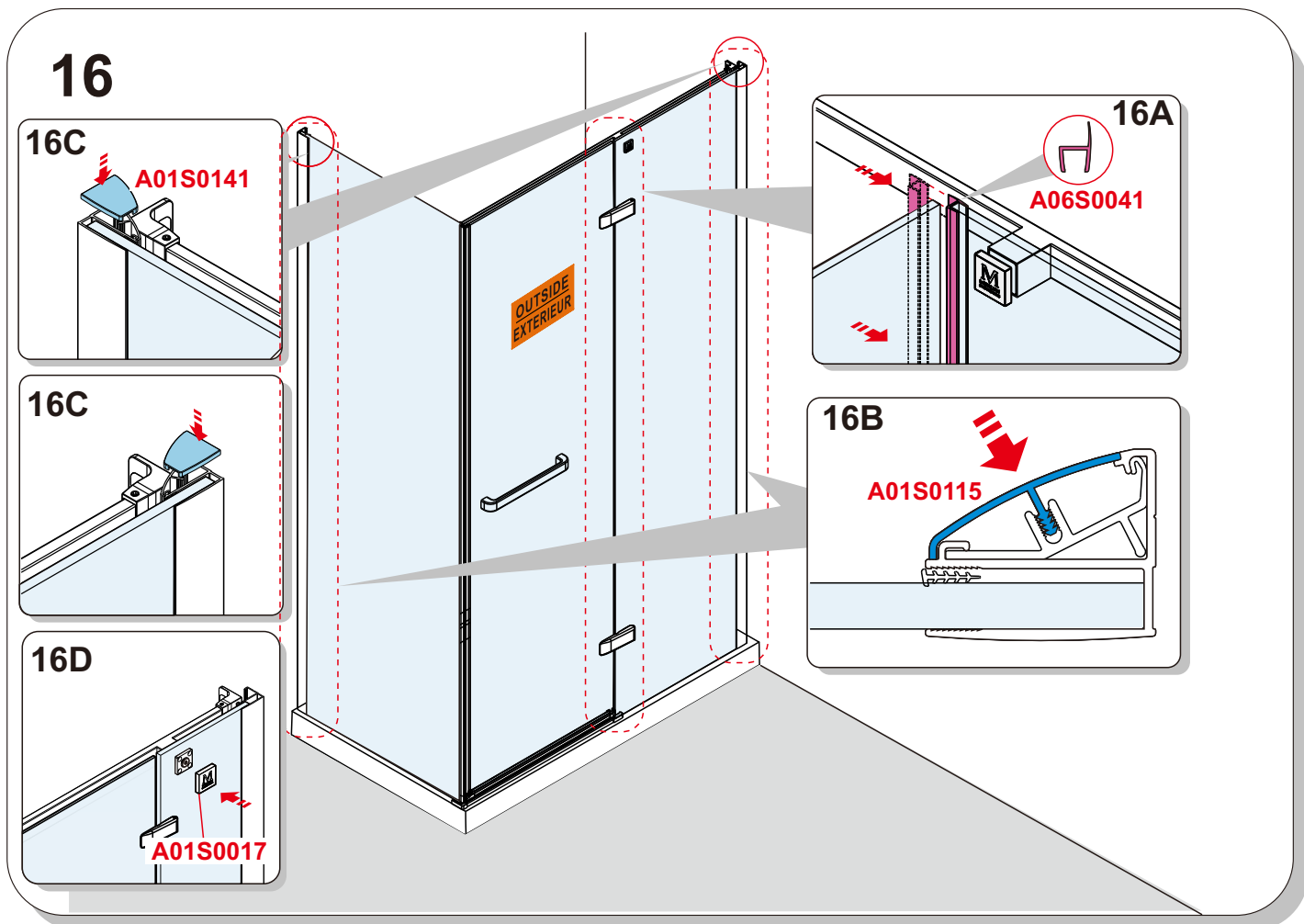
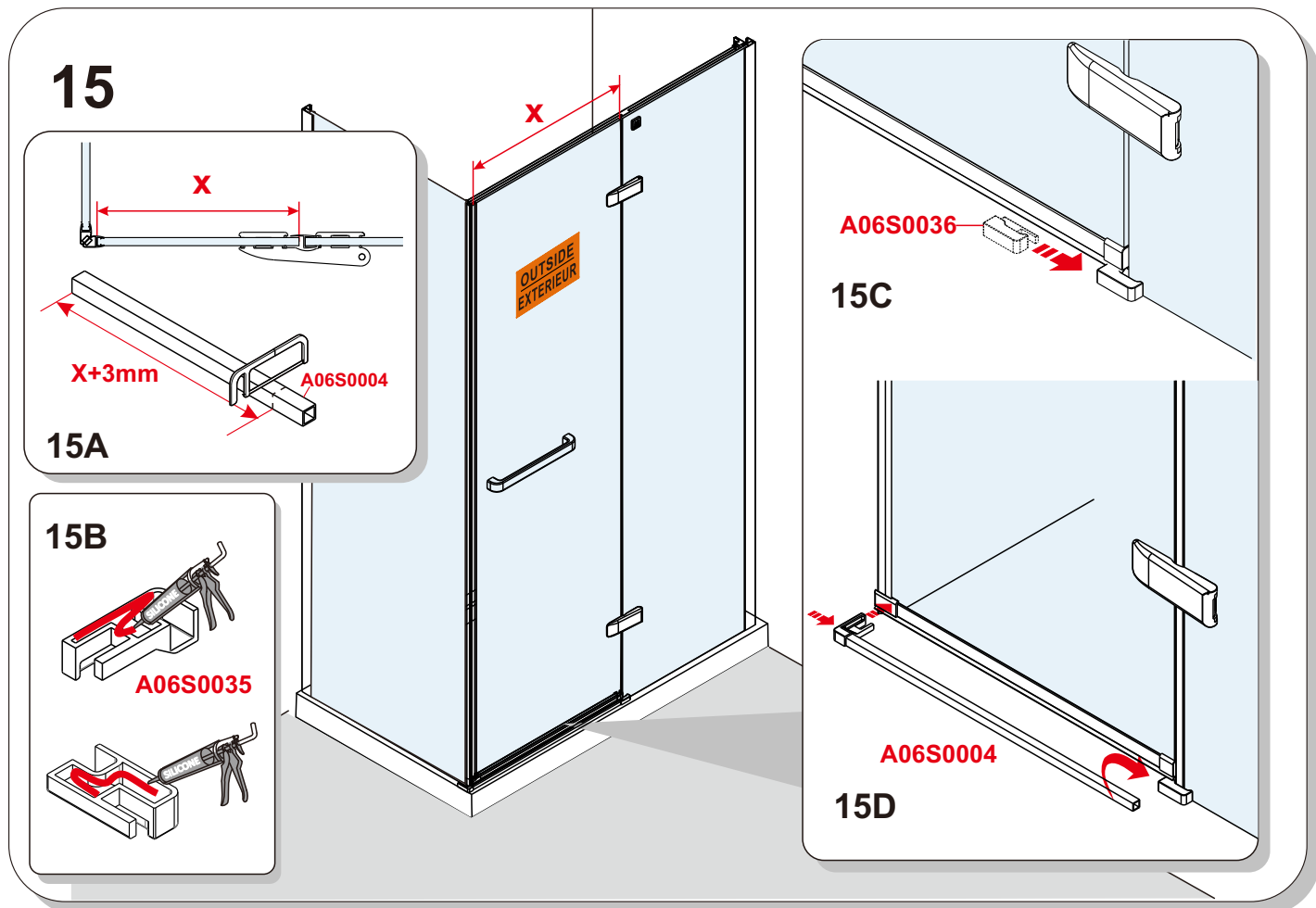

For further information please contact:
 Pour plus d'informations, contacter s'il vous plaît:
 Für weitere Informationen kontaktieren Sie bitte:
 Voor meer informatie, neem contact op met:

www.merlynshowering.com

IRL:0567791555

UK:08081011429

FR:0800916586