

# APOLLO malpensa wave vertical technical specification

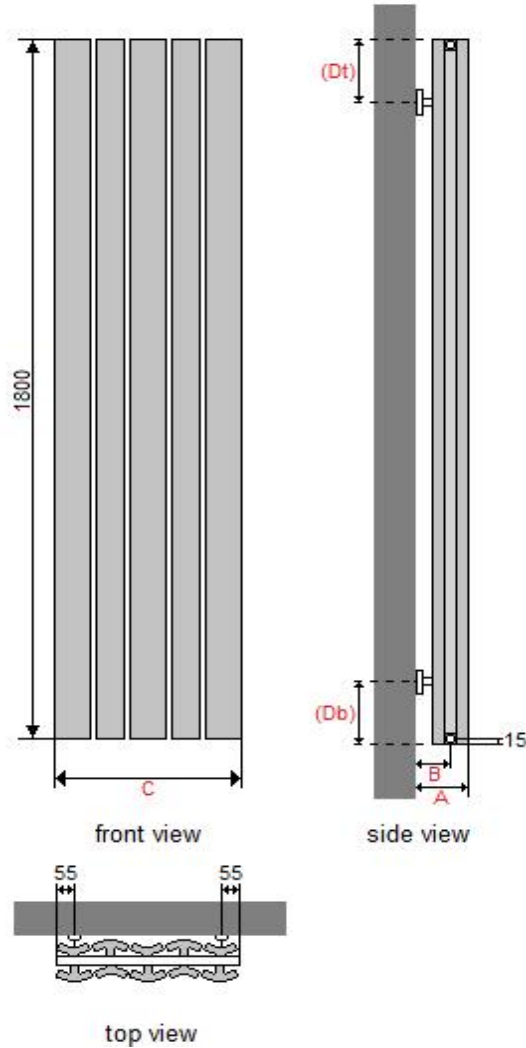

MALPENSA WAVE VERTICAL DIMENSIONS (mm)				
MODEL HEIGHT			1800	
Actual width of radiator		408	568	728
No. of sections		5	7	9
Section depth			80	
Section width	Wide section		88	
	Narrow section		70	
Back wall to front of rad	(A)		126	
Back wall to pipe centres	Side entry (B)		81	
	Bottom entry		N/A	
Tapping centres	Side entry (C)	408	568	728
	Bottom entry		N/A	
Bracket positions	Top (Dt)		150	
	Bottom (Db)		150	
Tappings			1/2"	

MALPENSA WAVE VERTICAL WEIGHTS AND VOLUMES (per radiator)			
Model Width (mm)	408	568	728
Dry Weight (A) Kg	16.00	22.40	28.80
Water content (B) Litres	1.90	2.70	3.40
Working weight (A+B) Kg	17.90	25.10	32.20
Outputs: Watts $\Delta T=50k$	1088	1523	1958

The thermal outputs expressed at  $\Delta T=50k$  comply with European regulation EN 442-2

ADDITIONAL INFORMATION	
Material	Aluminium
Alloy thickness	1.5mm
Maximum working pressure	16 bar
Maximum working temperature	90°C

TEMPERATURE FACTORS FOR DIFFERENCES BETWEEN MEAN WATER TEMPERATURE AND ROOM TEMPERATURE IN °C AND °F OTHER THAN 50°C (90°F)			
0.05	0.050		
10°C	0.123	10°F	0.057
15°C	0.209	20°F	0.142
20°C	0.304	30°F	0.240
25°C	0.406	40°F	0.348
30°C	0.515	50°F	0.466
35°C	0.629	60°F	0.590
40°C	0.748	70°F	0.721
45°C	0.872	80°F	0.858
50°C	1.000	90°F	1.000
55°C	1.132	100°F	1.147
60°C	1.267	110°F	1.298
65°C	1.406	120°F	1.454
70°C	1.549	130°F	1.613
75°C	1.694	140°F	1.776
TO APPLY THE FACTORS SHOWN IN THE TABLE TO OUR QUOTED OUTPUTS MULTIPLY THE QUOTED OUTPUT BY THE CHOSEN OPERATING FACTOR TO GIVE THE OUTPUT			