

# APOLLO malpensa curved vertical technical specification

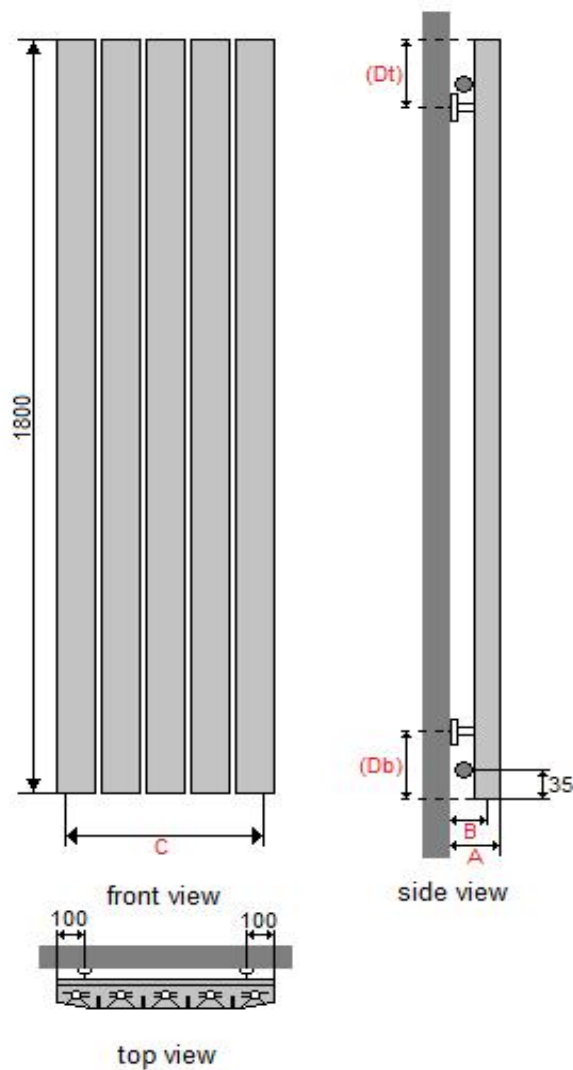

MALPENZA CURVED VERTICAL DIMENSIONS (mm)				
MODEL HEIGHT			1800	
Width of radiator			(No. of sections x 120) - 4	
No. of sections		3	4	5
Section depth x width		46 x 116		
Back wall to front of rad	(A)	84		
Back wall to pipe centres	Side entry (B)	25		
	Bottom entry	N/A		
Tapping centres	Side entry (C)	330	450	570
	Bottom entry	N/A		
Bracket positions	Top (Dt)	165		
	Bottom (Db)	165		
Tappings		1/2"		

MALPENZA CURVED VERTICAL WEIGHTS AND VOLUMES (per radiator)					
Model Width (mm)		356	476	596	716
Dry Weight (A) Kg		9.69	12.92	16.15	19.38
Water content (B) Litres		2.70	3.60	4.50	5.40
Working weight (A+B) Kg		12.39	16.52	20.65	24.78
Outputs: Watts $\Delta T=50k$		955	1273	1591	1909

The thermal outputs expressed at  $\Delta T=50k$  comply with European regulation EN 442-2

ADDITIONAL INFORMATION	
Material	Aluminium
Alloy thickness	1.5mm
Maximum working pressure	16 bar
Maximum working temperature	90°C

TEMPERATURE FACTORS FOR DIFFERENCES BETWEEN MEAN WATER TEMPERATURE AND ROOM TEMPERATURE IN °C AND °F OTHER THAN 50°C (90°F)			
0.05	0.050		
10°C	0.123	10°F	0.057
15°C	0.209	20°F	0.142
20°C	0.304	30°F	0.240
25°C	0.406	40°F	0.348
30°C	0.515	50°F	0.466
35°C	0.629	60°F	0.590
40°C	0.748	70°F	0.721
45°C	0.872	80°F	0.858
50°C	1.000	90°F	1.000
55°C	1.132	100°F	1.147
60°C	1.267	110°F	1.298
65°C	1.406	120°F	1.454
70°C	1.549	130°F	1.613
75°C	1.694	140°F	1.776

TO APPLY THE FACTORS SHOWN IN THE TABLE TO OUR QUOTED OUTPUTS MULTIPLY THE QUOTED OUTPUT BY THE CHOSEN OPERATING FACTOR TO GIVE THE OUTPUT