

# SPECIFICATION SHEET

COLLECTION: DX ELEMENTS  
PRODUCT CODE: ELE-148D/SQ-CP

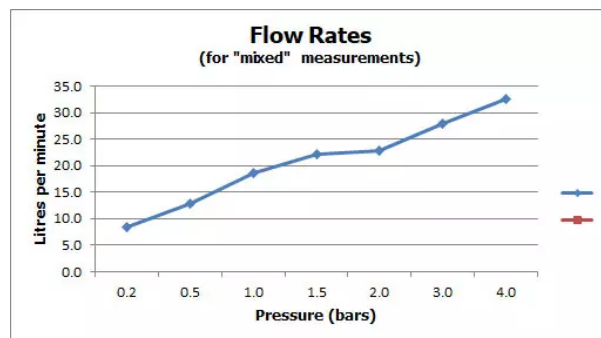

## SHOWER TYPE

Shower Valve

## VALVE TYPE

Concealed

## ORIENTATION

Vertical

## WITH ALL-FLOW FUNCTION

No

## WITH INTEGRATED DIVERTER

No

## COMPATIBLE WITH STUDFAST

Yes

## WITH BLEED VALVE FOR SYSTEM FLUSH ON INSTALLATION

Yes

## WITH SHOWER KIT

No

## INCLUDES MORTAR / TILE GUARD

Yes

tel: 01934 744466  
email: sales@vado.com  
www.vado.com

WHERE INSPIRATION FLOWS  
TAPS | SHOWERS | ACCESSORIES



# SPECIFICATION SHEET

COLLECTION: DX ELEMENTS  
PRODUCT CODE: ELE-148D/SQ-CP

## COMPATIBLE WITH EASY-FIX BRACKETS

No

## WITH THERMOSTATIC TECHNOLOGY

Yes

## INSTALLATION TOLERANCES

min-max wall mount 70-95mm optimum installation depth 82mm

## CONNECTIONS / FITTINGS

2 x 3/4" female inlets 1 x 3/4" female outlet includes 3/4" - 1/2" adaptors

## SPARE PARTS

thermostatic cartridge V-704-34S flow cartridge C-301-RTC

## MOUNTING

Wall Mounted

## PLUMBING SYSTEM SUITABILITY

Gravity System, Pumped System, Combination Boiler, Pressurised System

## COLLECTION NAME

DX Elements

## FINISH

Chrome

## MINIMUM OPERATING PRESSURE

0.2 Bar LP (Shower) / 1.0 Bar MP (Bath)

## GUARANTEE

15 Year Guarantee

# TECHNICAL DRAWING

COLLECTION: DX ELEMENTS  
PRODUCT CODE: ELE-148D/SQ-CP

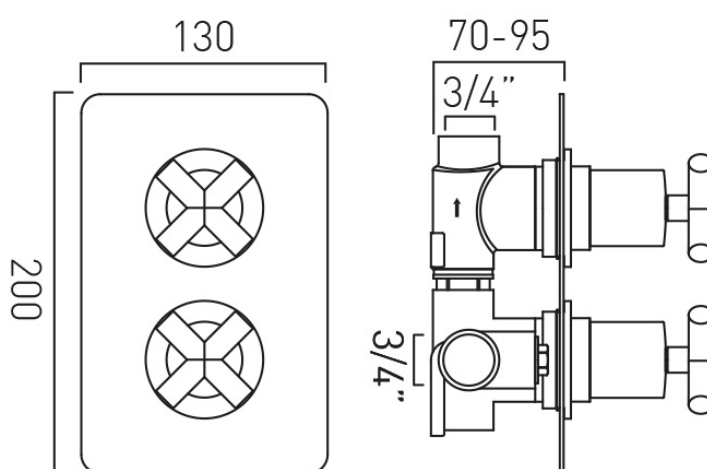

tel: 01934 744466  
email: sales@vado.com  
www.vado.com

WHERE INSPIRATION FLOWS  
TAPS | SHOWERS | ACCESSORIES

