

SPECIFICATION SHEET

COLLECTION: CAMEO

PRODUCT CODE: CAM-149T-RRK-MB

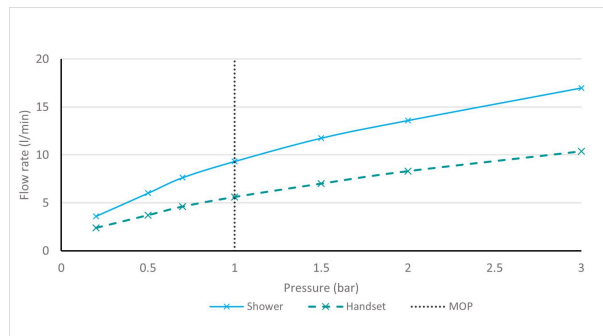

SHOWER TYPE

Shower Column

WITH AIR-INJECTION TECHNOLOGY

No

WITH CROSS-SPRAY TECHNOLOGY

No

ADJUSTABLE FIXING FOR EASY RETRO FIT

No

SHOWER HEAD SIZE

300mm x 200mm

WITH SHOWER KIT

No

VALVE TYPE

Exposed

WITH EASY-FIT BRACKETS

Yes

WITH INTEGRATED DIVERTER

Yes

tel: 01934 744466
email: sales@vado.com
www.vado.com

WHERE INSPIRATION FLOWS
TAPS | SHOWERS | ACCESSORIES



SPECIFICATION SHEET

COLLECTION: CAMEO

PRODUCT CODE: CAM-149T-RRK-MB

WITH THERMOSTATIC TECHNOLOGY

Yes

WITH WATER FLOW STRAIGHTENER

No

INSTALLATION TOLERANCES

476mm height adjustment tolerance: min 786mm – max 1262mm, 24mm depth adjustment tolerance: min 66mm – max 90mm

CONNECTIONS / FITTINGS

3/4" easy-fit brackets included

SPARE PARTS

thermostatic cartridge V-704-34S, flow cartridge C-801-33/2P

STYLE

Square

MOUNTING

Wall Mounted

PLUMBING SYSTEM SUITABILITY

Combination Boiler

COLLECTION NAME

Cameo

FINISH

Matt Black

MINIMUM OPERATING PRESSURE

1.0 Bar MP

MAXIMUM OPERATING PRESSURE

5.0 Bar HP

SPECIFICATION SHEET

COLLECTION: CAMEO

PRODUCT CODE: CAM-149T-RRK-MB

GUARANTEE

10 Year Guarantee

tel: 01934 744466
email: sales@vado.com
www.vado.com

WHERE INSPIRATION FLOWS
TAPS | SHOWERS | ACCESSORIES



TECHNICAL DRAWING

COLLECTION: CAMEO

PRODUCT CODE: CAM-149T-RRK-MB

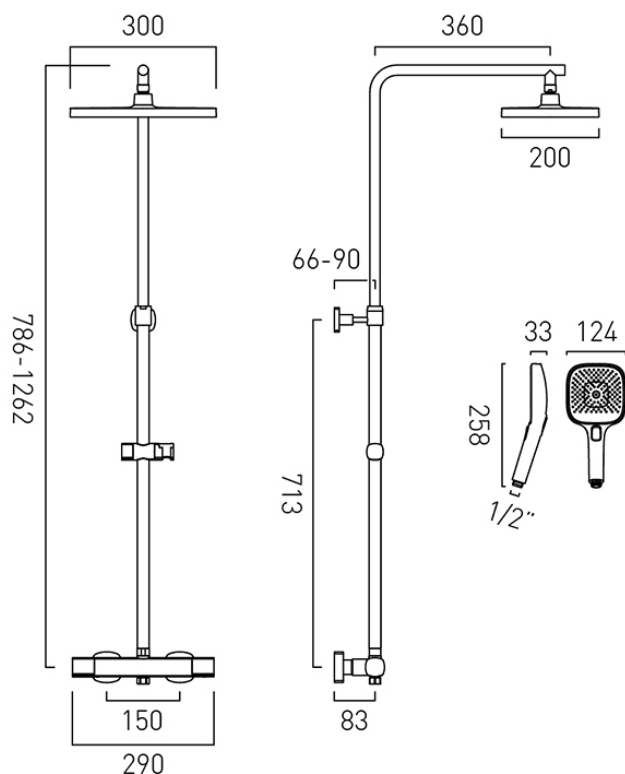

tel: 01934 744466
email: sales@vado.com
www.vado.com

WHERE INSPIRATION FLOWS
TAPS | SHOWERS | ACCESSORIES

