

SPECIFICATION SHEET

COLLECTION: CAMEO
PRODUCT CODE: CAM-149T-MW

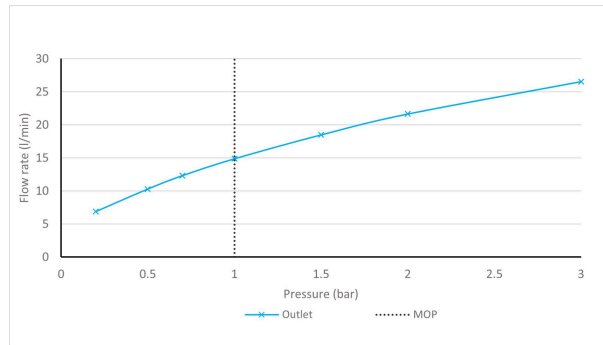
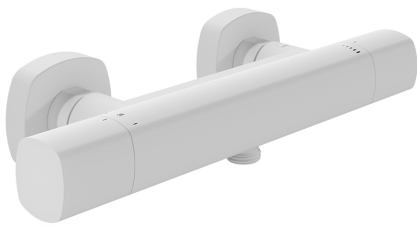

SHOWER TYPE

Shower Valve

VALVE TYPE

Exposed

STYLE

Square

ORIENTATION

Horizontal

NUMBER OF OUTLETS

1 Outlet

HANDLES

2 Handle

WITH ALL-FLOW FUNCTION

No

WITH INTEGRATED DIVERTER

No

COMPATIBLE WITH STUDFAST

No

tel: 01934 744466
email: sales@vado.com
www.vado.com

WHERE INSPIRATION FLOWS
TAPS | SHOWERS | ACCESSORIES



SPECIFICATION SHEET

COLLECTION: CAMEO

PRODUCT CODE: CAM-149T-MW

WITH BLEED VALVE FOR SYSTEM FLUSH ON INSTALLATION

No

WITH SHOWER KIT

No

INCLUDES MORTAR / TILE GUARD

No

COMPATIBLE WITH EASY-FIX BRACKETS

No

WITH THERMOSTATIC TECHNOLOGY

Yes

CONNECTIONS / FITTINGS

3/4" easy-fit brackets included

SPARE PARTS

thermostatic cartridge V-704-34S, flow cartridge C-303-RTC

MOUNTING

Wall Mounted

PLUMBING SYSTEM SUITABILITY

Combination Boiler

COLLECTION NAME

Cameo

FINISH

Matt White

MINIMUM OPERATING PRESSURE

1.0 Bar MP

SPECIFICATION SHEET

COLLECTION: CAMEO
PRODUCT CODE: CAM-149T-MW

MAXIMUM OPERATING PRESSURE

5.0 Bar HP

GUARANTEE

10 Year Guarantee

tel: 01934 744466
email: sales@vado.com
www.vado.com

WHERE INSPIRATION FLOWS
TAPS | SHOWERS | ACCESSORIES



TECHNICAL DRAWING

COLLECTION: CAMEO
PRODUCT CODE: CAM-149T-MW

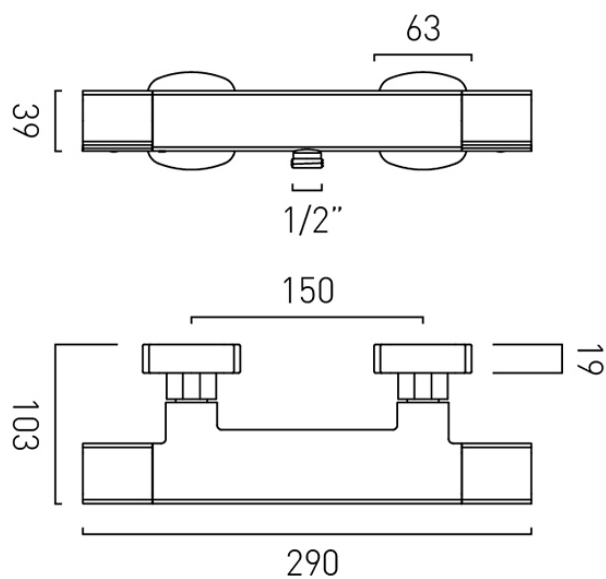

tel: 01934 744466
email: sales@vado.com
www.vado.com

WHERE INSPIRATION FLOWS
TAPS | SHOWERS | ACCESSORIES

