

Technical Data Sheet

ROPER RHODES®

STORM NOVA Mini Mixer With Click Waste - T466102

No.	Description	Code	Fixings Included
1	STORM NOVA Mini Mixer With Click Waste	T466102	YES



Min Pressure:	0.2bar
0.2bar	4.9 litres / min
0.3bar	5.9 litres / min
0.4bar	6.7 litres / min
0.5bar	7.5 litres / min
1bar	10.4 litres / min
2bar	14.7 litres / min

Dimensions:

Diagrams not to scale. All dimensions in mm (tolerance of +/-5mm)

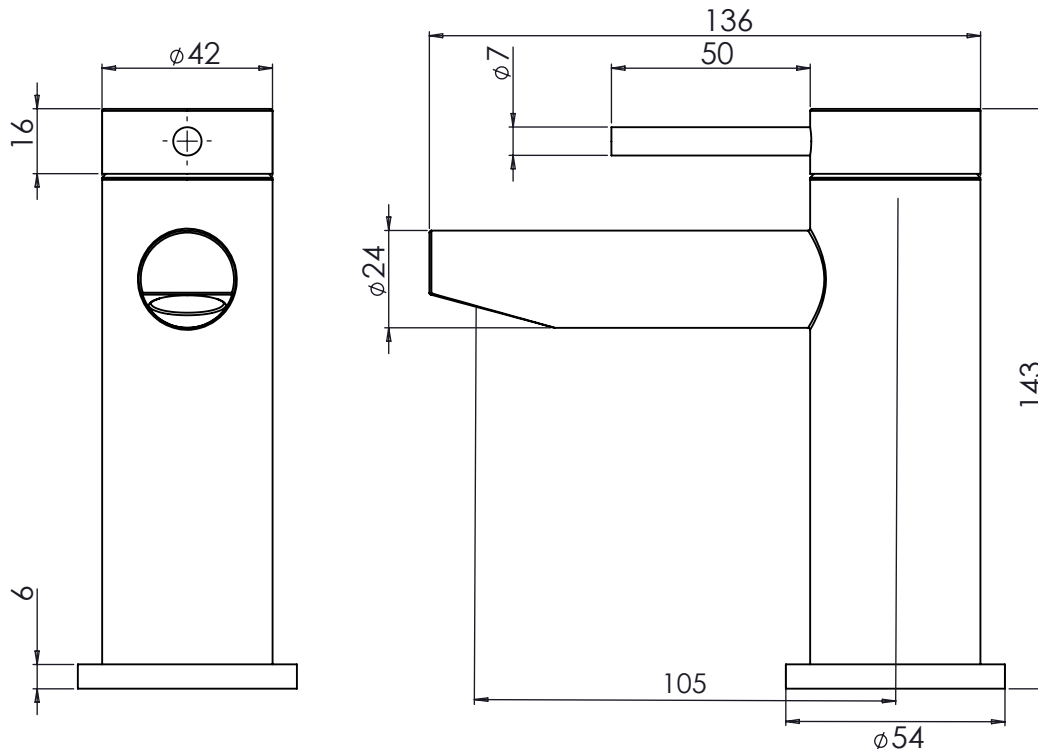

*Dimensions are subject to change, customers are advised to measure actual product before commencing installation.

FAQs

What is the size of the tap tail connection? The tap tails have a standard 1/2" BSP fixing.

What bore is the tap tail? The tails have a 10mm internal bore.

What length are the tap tails? The tails are 300mm in length.

Does the tap come fitted with an aerator? Yes, the aerator comes pre-installed but can be replaced.

What is the minimum recommended operating pressure of the tap? 0.2 bar