

Technical Specification Sheet

ENVOY 15

Stainless Steel 1.5 Bowl with Drainer

2216C



REGINOX

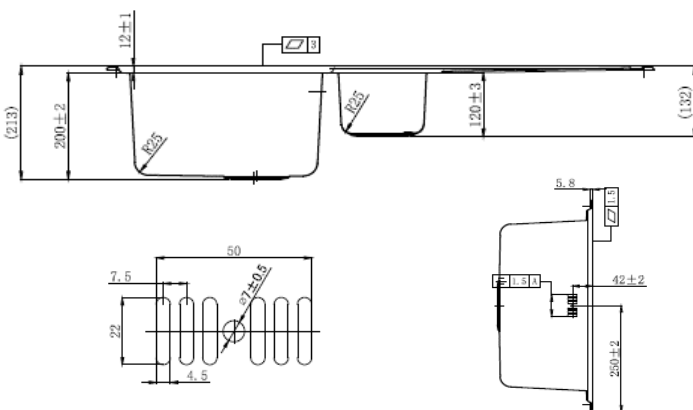
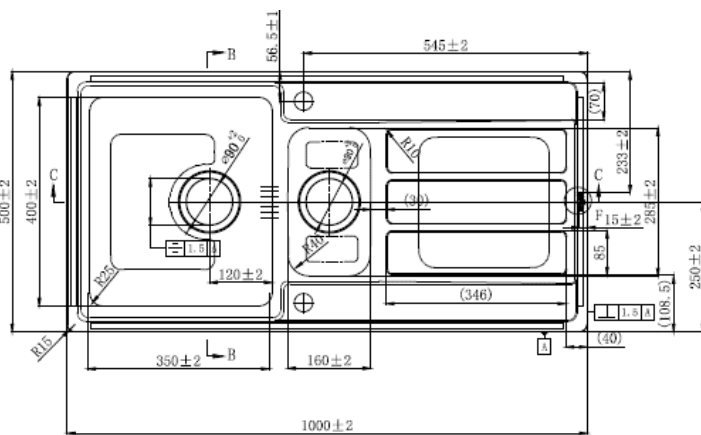
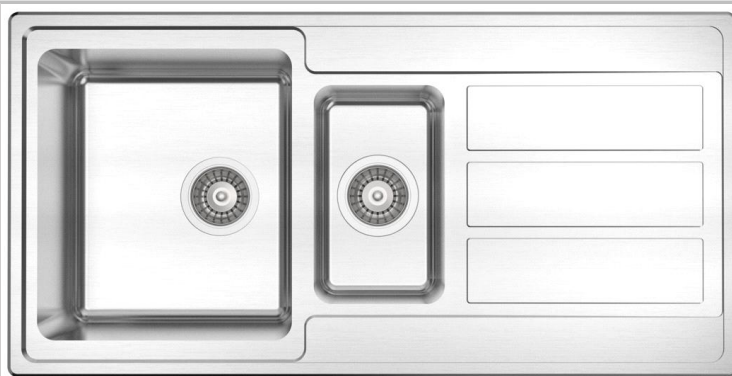

Specification

Material	Stainless Steel
Finish	Satin
Colour	Stainless Steel
Gauge	0.9
Welded/Pressed	Welded
No. of bowls	2
Fitting Method	Inset
Handing Options	Reversible
Cabinet Size (mm)	600
Overall Length (mm)	1000
Overall Width (mm)	500
Main Bowl Length (mm)	350
Main Bowl Width (mm)	400
Main Bowl Depth (mm)	200
Second Bowl Length (mm)	160
Second Bowl Width (mm)	285
Second Bowl Depth (mm)	120
Tap Hole Size (mm)	35
Waste Kit Included (Yes/No)	Yes
Clips & Seals Included (Yes/No)	Yes
Waste Size (mm)	90
Waste Kit Code	M 3081
Clips & Seals Code	N/A
Overflow Location	Main Bowl
Cut Out Length (mm)	980
Cut Out Width (mm)	480
Product Weight (kg)	5.1
Packed Weight (kg)	6
Packed Dimensions (mm)	1045x545x228
EAN number	8712465040249

Warranty

Lifetime on manufacturing | 1 years serviceable parts warranty (waste kit, clips & seals)

Care & Maintenance

Clean with warm soapy water only | You can use the Reginox INOX care cream to help maintain the steel finish | Avoid using anything abrasive on sink surface as will void the warranty