

PRSO108

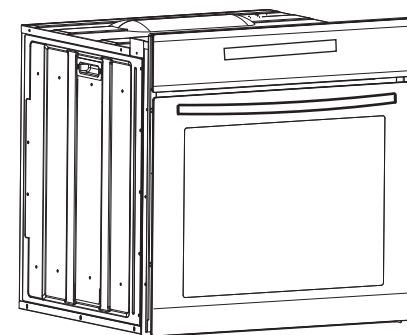

INSTRUCTION MANUAL

BUILT-IN ELECTRIC OVEN

Do not use the oven until you have read this instruction manual

DEAR CUSTOMER

Congratulations on your purchase. Our products are exceptionally easy to use and extremely efficient. After reading the instruction manual, operating the oven will be easy.

Before being packaged and leaving the manufacturer, the cooker was thoroughly checked with regard to safety and functionality.

These instructions have been compiled in order to help you learn how to handle the appliance. So please read them carefully before you use the appliance for the first time in order to avoid potential accidents.

Please keep the instruction manual and store it in a safe place so that it can be consulted at any time.

It is necessary to follow the instructions in the manual carefully in order to avoid potential accidents.

TABLE OF CONTENTS

Safety instructions.....	4
How to save energy.....	5
Disposal of the appliance.....	5
Unpacking.....	5
Description of the appliance.....	6
Installation.....	8
Operation.....	10
Prior to first use.....	10
Electronic programmer.....	10
Oven.....	15
Cleaning and maintenance.....	16
Operation in case of emergency.....	18
Baking in the oven.....	19
Technical information.....	25

SAFETY INSTRUCTIONS

- The appliance becomes very hot during operation. Take care not to touch the heating elements inside the oven.
- **WARNING:** Accessible parts may become hot during use. To avoid burns young children should be kept away.
- Mains lead of adjacent appliances may be damaged by hobs or trapped between the oven doors and produce a short circuit, therefore keep them at safe distance from the appliance.
- Never put pans weighing over 15Kg on the opened door of the oven.
- Do not use the oven in the event of a technical fault, once a technical fault is found, disconnect the power and report the fault to the service company.
- Never clean the oven with the high-pressure steam cleaning device, as it may cause a short circuit.
- Do not use harsh abrasive cleaners or sharp metal scrapers to clean the door glass as they can scratch the surface, which could then result in the glass shattering.
- The rules and provisions contained in this instruction manual should be strictly observed. Do not allow anybody who is not familiar with the contents of this instruction manual to operate the oven.
- During use the appliance becomes hot, care should be taken to avoid touching heating elements inside the oven.
- If the supply cord is damaged, it must be replaced by the manufacturer, its service agent or similarly qualified persons in order to avoid a hazard.
- The appliance is not intended for use by persons (including children) with reduced physical, sensory or mental capabilities, or lack of experience and knowledge, unless they have been given supervision or instruction concerning use of the appliance by a person responsible for their safety.
- Children should be supervised to ensure that they do not play with the appliance.
- **WARNING:** Ensure that the appliance is switched off before replacing the lamp to avoid the possibility of electric shock.
- Children less than 8 years of age shall be kept away from the appliance when it is operating.
- Children shall not play with the appliance.
- **WARNING:** Accessible parts may become hot during use.
- Young children should be kept away
- During use the appliance becomes hot. Care should be taken to avoid touching heating elements inside the oven

HOW TO SAVE ENERGY



Using energy in a responsible way not only saves money but also helps the environment.

So let's save energy! And this is how you can do it:

- Make use of residual heat from the oven. If the cooking time is greater than 40 minutes, switch off the oven 10 minutes before the end time. Important when using the timer, set appropriately shorter cooking times according to the dish being prepared.
- Make sure the oven door is properly closed. Heat can leak through spillages on the door seals. Clean up any spillages immediately.
- Do not install the oven in the direct vicinity of refrigerators/freezers. Otherwise energy consumption increases unnecessarily.

UNPACKING

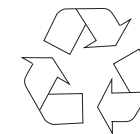

During transportation, protective packaging was used to protect the appliance against any damage.

After unpacking, please dispose of all elements of packaging in a way that will not cause damage to the environment. All materials used for packaging the appliance are environmentally friendly; they are 100% recyclable and are marked with the appropriate symbol.

Caution!

During unpacking, the packaging materials (polythene bags, polystyrene pieces, etc.) should be kept out of reach of children.

DISPOSAL OF THE APPLIANCE



Old appliances should not simply be disposed of with normal household waste, but should be delivered to a collection and recycling centre for electric and electronic equipment.

A symbol shown on the product, the instruction manual or the packaging shows that it is suitable for recycling.

Materials used inside the appliance are recyclable and are labeled with information concerning this. By recycling materials or other parts from used devices you are making a significant contribution to the protection of our environment.

Information on appropriate disposal centres for used devices can be provided by your local authority.

DESCRIPTION OF THE APPLIANCE

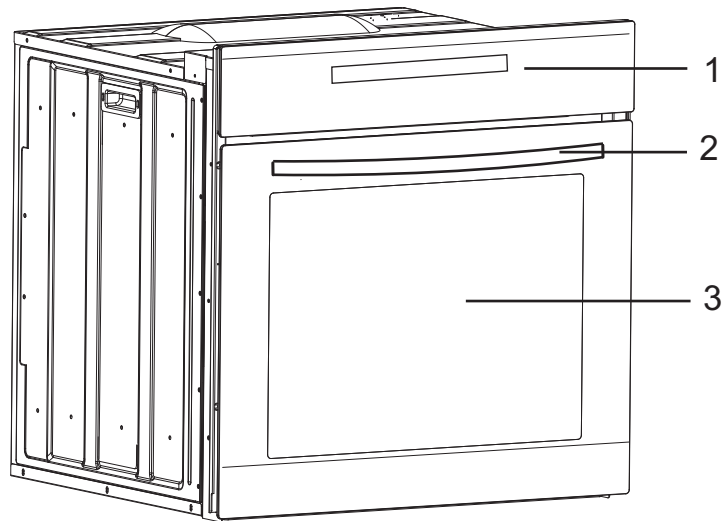

1. Control panel
2. Oven door handle
3. Oven door

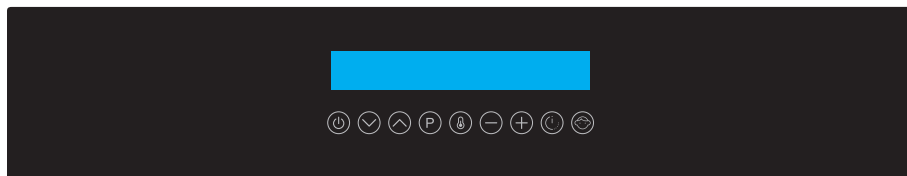

INSTALLATION

▷ Installing the oven

- The kitchen should be dry and have effective ventilation according to the existing technical provisions.
- Main lead behind the oven must be placed in such manner to avoid touching the back panel of the oven because of the heat it develops during operation.
- Remove any packaging materials (foils, artificial foam, etc.) from the reach of children, because they represent potential danger. Children may swallow small parts, or suffocate with foils.
- This is a built-in oven, which means that its back wall and one side wall can be placed next to a high piece of furniture or a wall. Coating or veneer used on fitted furniture must be applied with a heat resistant adhesive (100°C). This prevents surface deformation or detachment of the coating. If you are unsure of your furniture's heat resistance, you should leave approximately 2cm of free space around the oven. The wall behind the oven should be resistant to high temperatures. During operation, its back side can warm up to around 50°C above the ambient temperature.
- Make an opening with the dimensions given in the diagram for the oven to be fitted.
- The appliance must be earthed.
- Insert the oven completely into the opening without allowing the four screws in the places shown in the diagram to fall out.

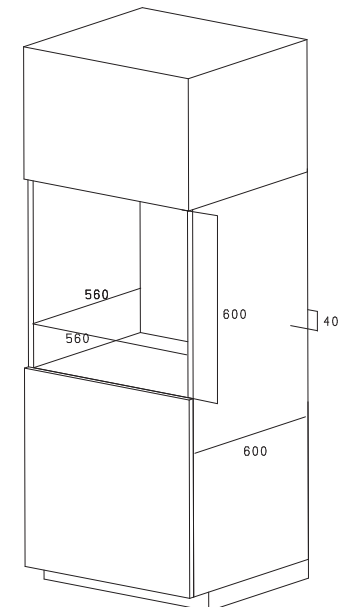
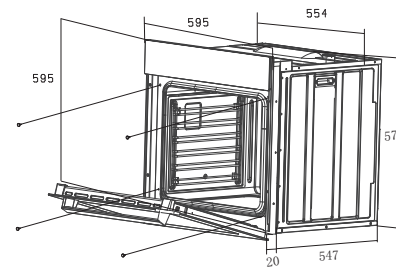

INSTALLATION

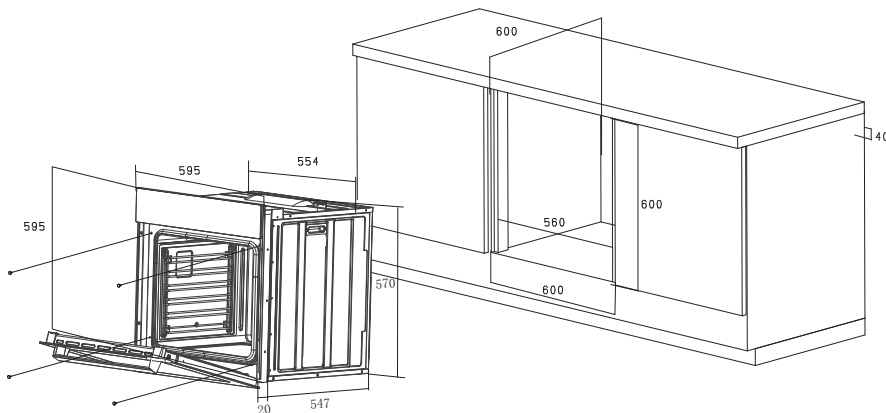

Electrical connection

Warning!

All electrical work must be carried out by a suitably qualified and authorized electrician. No alterations or willful changes in the electricity supply should be carried out.

- Before attempting the connection, check whether the voltage indicated on the rating plate corresponds to the actual mains voltage.
- Mains lead should be minimum 1.5m long.
- Earth wire should be installed in such a manner to be the last one pulled out in case the safety device on the mains lead should fail.
- Mains lead behind the oven must be located to avoid touching the back panel of the oven because of the heat it develops during operation.
- The correct size cable rating must be used cable type HO5RR-F 3 × 1.5m². The earth wire shall be longer than the other wires.
- Disconnection from the supply mains must have a contact separation in all poles that provide full disconnection under over voltage

fixed wiring in accordance with the wiring rules.

Connection (by authorised electrician)

- Using the screwdriver open the connector cover at the rear of the appliance. Release two locks located at either side of the connector bottom.
- Mains lead must be led through the relief safety device, protecting the mains lead cable from disconnection.
- Tighten the relief device securely and close the connector cover.

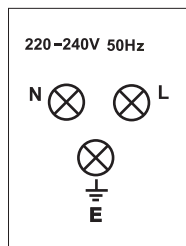
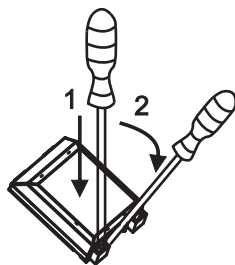

Colour code
L1= exterior live wires, usually coloured black, brown.
N=neutral
The colour is usually blue.
Beware of the correct N-connection!
E = earth wire, the colour is green/yellow.

OPERATION

Prior to first use

- Remove packaging, clean the interior of the oven.
- Take out and wash the oven fittings with warm water and a little soap
- Switch on the ventilation in the room or open a window.
- Heat the oven (to a temperature of 250°C, for approx. 30 min.), remove any stains and wash carefully.

Caution!

When heating the oven for the first time, it is normal for it to give off smoke and a peculiar smell. This will disappear in about 30 min later.

Electronic programmer

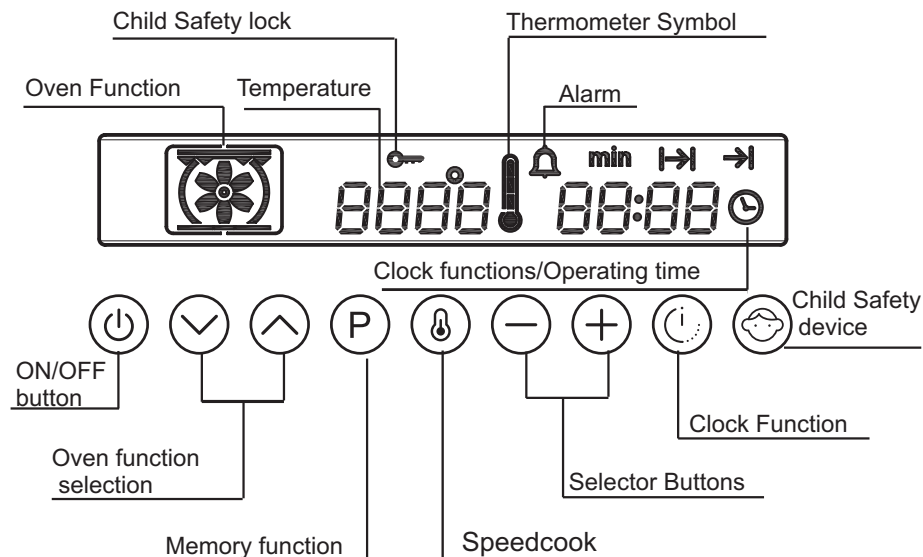



General instructions



- .Always switch the oven on first by pressing the ON/OFF button.
- .When the desired function is set, 5 seconds later, the oven will heat up or the time set begins to count down.
- .The oven light is permanently on when in operation.

OPERATION



Selecting the oven function

- .Switch on the oven with the ON/OFF  button.
- .Press the  or  button until the desired oven function appears.
- .A suggested temperature will appear on the temperature display.
- .If the suggested temperature is not changed within approx 5 seconds, the oven begins to heat up.



Changing the oven temperature

- .Press the  or  button to raise or lower the temperature.
- .The setting changes in steps of 5°C

Thermometer symbol

- .The slowly raising thermometer symbol  indicates the oven is heating up.
- .The three segments of the thermometer symbol  show that Speedcook is working.

Changing the oven function

- .To change the oven function ,Press the  or  button repeatedly until the desired oven function is displayed.



Switching off the oven

- .Switch off the appliance using the ON/OFF  button.

Speedcook

After an oven function is selected,using the speedcook function  to pre-heat the oven in a short time frame.

Important: Do not put food into the oven **until speedcook is completed** and the oven is operating using the desired function.

- 1.Set the desired function .If necessary change the suggested temperature.
- 2.Press the speedcook  button ,the symbol  flashing.
The bars flashing one after another shows that speedcook is operating.
When the set temperature is reached ,the bars of the heat indicator stop flashing.

The oven now continues heating according to pre-set oven function and temperature.

You can now place the food in the oven.

OPERATION



Memory function

The memory function can be used to save a setting which is frequently used.

- 1.Set oven function,at the same time the temperature is flashing.
- 2.Press the button  when temperature flashing, then an acoustic signal sounds,The setting is saved.

To save another setting press the button  when the temperature is flashing.The new one replaces the previously saved setting .

Starting the Memory function

- 1.Switch the oven on using the button On/Off  .
- 2.Using the button  recall the saved setting.

Clock Function

Count down

A alarm sounds after the time has elapsed.
This function does not affect the operation of the oven.

Cook time

To set how long the oven is to be running.



End time

To set when the oven is to switch off.



Time

To set ,change or check the time.

General instructions



.After a clock function has been selected,the corresponding symbol flashes for a few seconds. During this time, the desired time can be set or modified using the  or  button.



.When the desired time has been set, the symbol continues to flash for approx.5 seconds.After this the symbol lights up, the set countdown  begins.

.The time set for cook time  and  end time begins to count down after the selected function starts.

OPERATION

Countdown

1.press the clock Functions  button repeatedly until the symbol for Countdown  flashes.

2.Set the desired Countdown time using the  or  button(max.23h55minutes). After approx. 5 seconds the display shows the time remaining,The symbol for countdown  lights up.



When the time set has elapsed a alarm sounds for 90 seconds.



"0.00" is displayed and symbol for countdown  flashes.

To turn off the alarm press  button.

Cook time

1.select oven function and using  or  button select temperature.

2.Press the Clock Function  button repeatedly until the symbol for cook time  flashes.

3.using the  or  button,set the desired cooking time.The oven will switch itself on.

The symbol for cook time  lights up.

By repeatedly pressing the Clock Function  button,the current time can be recalled. When the time has elapsed,a alarm will sound for 60 seconds.



The oven will switch itself off.



:0.00" is displayed the symbol for Cook time  flashes

To turn off the alarm press  button.

End time

1.Selected oven function and using  or  button ,select temperature.

2.Press the Clock Function button  repeatedly until the symbol for End time  flashes.

3.Using the  or  button set desired switch-off time.The symbols for end time  light up.

The oven will automatically switch itself on.

Cook time and End time combined

Cook time and end time can be used simultaneously, if the oven is to be switched on and off automatically at a later time.

1.Select oven function and temperature.

2.Using the Cook function, set the time you desired . e.g.1 hour.

3.Using the End time function, set the time at which you wish the oven to turn off. e.g.14:05.

OPERATION

The symbols for Cook time and End time light up .

The oven switches on-automatically at the time desired . e.g.13:05.

When the set cooking time has elapsed, an alarm sounds for 60 seconds. e.g.14:05.

The oven will switch itself off.

Other Functions

Child safety device

As soon as the child safety device is engaged,the appliance can no longer be switched on.

Either the on/off button is on or off,you can active and deactivated the child safety device.

Automatic shut-off feature

Each mode has a maximum working time, auto shut-off feature noted in the following criteria:

Temperature selection	Limitation of working hours
20–120°C	24h
121–200°C	6h
201–250°C	4h



Smart Cooling Function

When the oven internal temperature reaches the set level, the top of the cooling fan running to the internal space and cooling components.

Mode Settings

Long press  button 5 seconds to enter mode settings:

Press  or  button to select the desired setting mode (mode 1-5) .

By pressing  and  button to select a mode (In0-In1). After setting, press the  button to confirm the setting.

Mode	Selection	In 0	In 1	Remarks
Mode1	Child safety device	The screen is unlocked after power	The screen is locked after power	This control panel will be used only to mode1 and mode2,the remaining three models for the reserved function, can not operate.
Mode2	Time display	The clock no longer displayed after 20S	The clock always displayed	

OPERATION



Full Grill (Grill and the top element)

When the “combined grill” is active it enables grilling with the grill and with the top element switched on at the same time.

This function allows a higher temperature at the top of the cooking area, which causes more intense browning of the dish and permits larger portions to be grilled.

Warning!

When using function Grill it is required that the oven door is closed.

Warning!

When the grill is in use accessible parts can become hot. It is best to keep children away from the Oven.



Bottom and top element on

Setting this function allows the oven to be heated conventionally.



Bottom element

At this oven position , the oven activates the bottom element .



Fan, bottom and top element on

At this position the oven operates as a conventional oven with a fan.



Fan(Defrost)

At this position, the fan only works. Auxiliary rear heater works for a shorttime . You can cool the dish or the oven cavity or defrost food.



Economy Grill (variable) (1100w)

Use the economy grill to grill or brown small amounts of food. Locate the grill pan in the 4th or 5th shelf position . pre-heat the grill for 5 minutes before use .



Fan and bottom heater on

At this oven position , the oven activates the bottom heater and fan function.

The mode is useful for baking flat pastry and preparation of preserved fruit and vegetables.



Fan, grill element

The oven activates the grill top heater and fan function. In practice, this function allows the grilling process to be speeded up , You should only use the grill with the oven door shut.

OPERATION



Circular heater Fan with Bottom Element

This operates the fan oven with the convection element and the bottom element allowing for cooking with increased temperature from the bottom of the dish when using shelf position 3 or 4 . set the oven operation knob to . The default temperature of 220 °C is displayed and can be adjusted using the and buttons.



Circular heater Fan

At this position the oven can be heated up in a forced way with the thermofan , which is in the central part of the oven cavity. Heating the oven up in this way permits circulation around the dish that is in the oven. The advantage of this heating method is:

- reduction of oven heating-up time and of the initial heating stage.
- Possibility to bake at two cooking levels simultaneously.
- Reduction in the amount of fats and juices coming out of meat dishes , which results in an improvement in taste.

Oven guide levels

Baking pans and accessories (oven grid, baking tray, etc) may be inserted into the oven at 6 shelf position. Appropriate levels are indicated in the tables that follow. Always count levels from the bottom upwards!

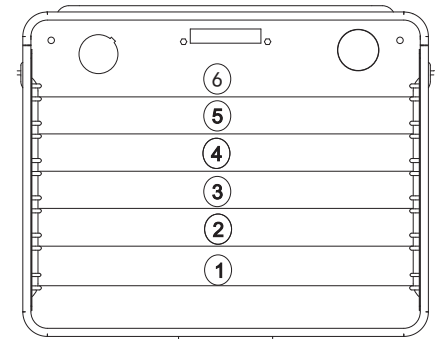

CLEANING AND MAINTENANCE

Proper cleaning and maintenance of your oven can have a significant influence on the continuing fault-free operation of your appliance.

Before you start cleaning, the oven must be switched off and you should ensure that all knobs are set to the "0" position. Do not start cleaning until the oven has completely cooled.

▷ Oven

- The oven should be cleaned after each use.
- Cool the oven completely before cleaning.
- Never clean the appliance with pressurized hot steam cleaner.
- The oven chamber should only be washed with warm water and a small amount of washing-up liquid.

Caution!

Do not use cleaning products containing abrasive materials for the cleaning and maintenance of the glass front panel.

CLEANING AND MAINTENANCE

▷ Replacement of the oven light Bulb

Before any maintenance is started involving electrical parts, the appliance must be disconnected from the power supply.

If the oven has been in use, let the oven cavity and the heating elements cool down before attempting any **maintenance**.

Changing the bulb

- Pull out the protective cover. We recommend that you wash and dry the glass cover at this point.
- Carefully remove the old bulb and insert the new bulb suitable for high temperatures (300°C) having the following specifications: 230-240V, 50Hz, 25W, G9 fitting.
- Refit the protective cover.

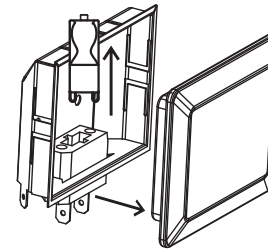

IMPORTANT

Never use screwdrivers or other utensils to remove the light cover. This could damage the enamel of the oven or the lampholder. Remove only by hand.

IMPORTANT

Never replace the bulb with bare hands as contamination from your fingers can cause premature failure. Always use a clean cloth or gloves.

Please note:

The bulb replacement is not covered by your guarantee

▷ Door removal

In order to obtain easier access to the oven cavity for cleaning, it is possible to remove the door.

To do this, tilt the safety catch part of the hinge upwards. Close the door lightly, lift and pull it out towards you. In order to fit the door back on to the cooker, do the reverse. When fitting, ensure that the notch of the hinge is correctly placed on the protrusion of the hinge holder. After the door is fitted to the oven, the safety catch should be carefully lowered down again. If the safety catch is not set it may cause damage to the hinge when closing the door.

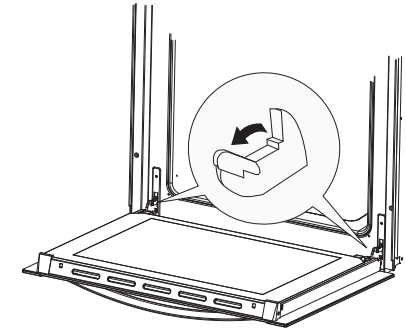

Tilting the hinge safety catches

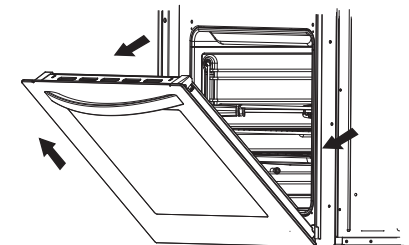

Door removal

CLEANING AND MAINTENANCE

▷ Removal of the internal glass panel

Press the symbol  and outward the plastic latch that is in the corner at the top of the door. Next take out the glass from the second blocking mechanism and remove. After cleaning, insert and block the glass panel, and insert in the blocking mechanism.

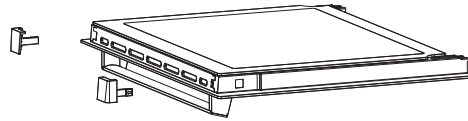

Removal of the internal glass panel

▷ Install door

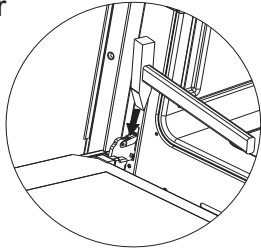

OPERATION IN CASE OF EMERGENCY

In the event of an emergency, you should:

- Switch off the oven at the power supply
- Call the service company.
- Some minor faults can be fixed by referring to the trouble shooting given in the table below. Before calling the customer support centre or the service company check the following points that are presented in the table.

PROBLEM	REASON	ACTION
1. The appliance does not work.	Break in power supply.	Check the household fuse box; if there is a blown fuse replace it with a new one
	Choose wrong function.	Check if function knob ,temperature Knob is set to the correct position.
2. The programmer display is flashing"0.00".	The appliance was disconnected from the mains or there was a temporary power cut.	Set the current time (see Use of the programmer)
3. The oven lighting does not work.	The bulb is loose or damaged.	Tighten up or replace the blown bulb (see Cleaning and Maintenance')

BAKING IN THE OVEN

▷ Baking pastry

Most appropriate for baking is using both upper and lower heater, or the hot air.

Warning!

- The baking parameters given in Tables are approximate and can be corrected based on your own experience and cooking preferences;
- In case you do not find a particular type of cake in the tables, use the information available for the next most similar type of cake.

Baking with upper and lower elements

- Use only a single guide level.
- This baking position is especially suitable for baking dry pastry, bread and teacakes. Use dark baking pans. Light pans reflect heat and pastry is not adequately browned.
- Always place baking pans on the grid rack. Remove the grid only if baking with the flat tray, supplied with the appliance.
- Preheating shortens the baking time. Do not put the cake in the oven until correct temperature is reached .

Baking tips

Is cake baked?

Pierce the cake with a fork at the thickest part, if it does not stick to it, the cake is baked. You may switch off the oven and use the remaining heat.

Cake has dropped

Check the recipe. Use less liquid next time. Follow the mixing times, especially when using electric kitchen mixers.

Cake is too light on the bottom

Use dark baking pan next time, or place the pan one level lower, or switch on the lower heater a while before the completion.

Cheese cake is undercooked



Next time reduce the baking temperature and extend the baking time.

Warnings regarding the baking tables

- The tables indicate the temperature range. Always select lower temperature first. You may always increase the temperature in case pastry needs more baking.
- Baking times are indicative only.
- The asterisk indicates that the oven requires preheating.

BAKING IN THE OVEN

Pastry Baking Table

Type of pastry	Guide level (from down upwards)	Temp (°C) 	Guide level (from down upwards)	Temp(°C) 	Baking time (in min.)
Sweet pastry					
Raisin cake	2	160-170	2	150-160	55-
Ring cake	2	160-170	2	150-160	60-70
Cake (tart form)	2	160-170	2	150-160	45-60
Cheese cake (tart form)	2	180-190	3	160-170	60-80
Fruit cake	2	190-200	3	170-180	50-70
Fruit cake with icing	2	180-190	3	160-170	60-70
Sponge cake	2	180-190	2	160-170	30-40
Flake cake	3	190-200	3	170-180	25-35
Fruit cake mix dough	3	180-190	3	160-170	50-70
Cherry cake	3	190-210	3	170-200	30-50
Fruit fan	3	160-170	3	150-160	25-35
Plait bun	2	190-210	3	180-210	35-50
Christmas cake	2	180-190	3	170-200	45-70
Apple pie	2	190-210	3	170-200	40-60
Puff pastry	2	180-190	3	160-170	40-60
Salted pastry					
Pizza	2	220-240	3	210-230	30-45
Bread	2	200-220	3	180-210	50-60
Rolls	2	210-230	3	200-220	30-40
Cookies					
Biscuits	3	180-190	3	160-170	20-30
Danish pastry	3	190-210	3	170-200	20-35
Flaky pastry	3	200-210	3	180-200	20-30
Cream puff	3	190-210	3	170-200	25-45
Deep frozen pastry					
Apple pie, cheese pie	2	190-210	3	170-200	50-70
Cheese cake	2	190-200	3	170-180	65-85
Pizza	2	210-230	3	200-220	20-30
Chips for oven	2	210-230	3	200-220	20-35

BAKING IN THE OVEN

▷ Roasting

Best results are obtained with by using both upper and lower elements .
Best heating mode for each type of roasting pan is indicated by bold print in the Roasting Tables.

Tips regarding roasting pans

- For best results, use light enamel pans, temperature resistant glass pans, clay dishes or cast iron dishes.
- As stainless steel dishes reflect the heat, they are not recommended.
- If you cover your roast or wrap it in foil, it will preserve its juices and the oven will remain clean.
- The roast will be cooked quicker if it is left uncovered. Large roasts can be placed directly on the grid with the oven tray below for catching the juices and melted fat.



Attention when roasting!

Roasting tables indicate suggested temperatures, guide level and roasting times. Roasting time largely depends upon the type of meat, its size and quality. So you may expect some variations

- Roasting of large chunks of meat may produce excessive steaming and condensation on the oven door. This is quite normal, and does not affect the operation of the oven.
However, after the completion of roasting wipe the oven door and the glass thoroughly.
- Add as much liquid as necessary to prevent burning of juice, dripping from meat. Roast must be checked regularly and liquid added if necessary.
- At approximately the middle of the indicated time turn the roast round, especially if you use the deep roast dish.
- When roasting on the grill grid, place the grid in the deep roasting pan and insert both into the sliding guide. The bottom pan will intercept dripping fat.
- Never leave roast to cool in the oven, as it might produce condensation and corrosion of the oven.

BAKING IN THE OVEN

Roasting table

Type of meat	Weight (in grams)	Guide level (from bottom up)	Temp (°C) 	Roasting time (in min.)	temp (°C) 	Roasting time (in min.)
Beef						
Beef loin	1000	2	210-230	2	200-220	100-120
Beef loin	1500	2	210-230	2	200-220	120-150
Roast beef, rare	1000	2	230-240	2	220-230	30-40
Roast beef, well done	1000	2	230-240	2	220-230	40-50
Pork						
Pork roast with skin	1500	2	190-200	2	170-180	140-160
Flank	1500	2	200-210	2	180-190	120-150
Flank	2000	2	190-210	2	170-200	150-180
Pork loin	1500	2	210-230	2	200-220	120-140
Meat roll	1500	2	210-230	2	200-220	120-140
Pork cutlet	1500	2	190-210	2	170-200	100-120
Minced meat roast	1500	2	220-230	2	210-220	60-70
Veal						
Veal roll	1500	2	190-210	2	170-200	90-120
Veal knuckle	1700	2	190-210	2	170-200	120-130
Lamp						
Lamp prime ribs	1500	2	200-210	2	180-200	100-120
Mutton blade bone	1500	2	200-210	2	180-200	120-130
Venison						
Hare ribs	1500	2	200-220	2	180-210	100-120
Hare blade bone	1500	2	200-220	2	180-210	100-120
Boar ham	1500	2	200-220	2	180-210	100-120
Poultry						
Chicken entire	1200	2	210-220	2	200-210	60-70
Hen	1500	2	210-220	2	200-210	70-90
Duck	1700	2	190-210	2	170-200	120-150
Goose	4000	2	170-180	2	150-160	180-200
Turkey	5000	2	160-170	2	140-150	180-240
Fish						
Fish, entire	1000	2	210-220	2	200-210	50-60
Fish soufflé	1500	2	190-210	2	170-200	50-70

BAKING IN THE OVEN

Grilling

- Take extra precautions when grilling. Intensive heat from infrared element makes the oven and the accessories extremely hot. Use protective gloves and accessories!
- Perforated roast may produce spurting of hot grease (sausages). Use long grill tongs to prevent skin burns and protect your eyes.
- Supervise the grill at all time. Excessive heat may quickly burn your food and provoke fire!
- Do not let the children in the vicinity of the grill.

Grill heater is especially suitable for the preparation of low-fat sausages, meat and fish fillets and steaks, and for browning and crisping the roast skin.

Tips for grilling

- Grilling should be carried out with the oven door closed.
- Grilling tables indicate the recommended temperature, guide levels and grilling times, which may vary according to the weight and quality of meat
- Grill element should be pre-heated for 3 minutes.
- Oil the grill grid before placing food on it, to avoid food sticking to the grid.
- Place the meat upon the grid, then place the grid upon the grease interception pan. Insert both trays into the oven guides.
- Turn the meat round after half of the grilling time has expired. Thinner slices will require only one turn, for larger chunks you might need to repeat the procedure. Always use tongs to avoid losing excessive juice from meat.
- Dark beef meat is grilled quicker than lighter pork or veal.
- Clean the grill, the oven and the accessories each time after use.

BAKING IN THE OVEN

Grill table

Type of meat for grill	Weight (in grams)	Guide level (from bottom up)	Temp (°C) 	Grill time (in min.)
Meat and sausages				
2 beefsteaks, rare	400	5	240	14-16
2 beefsteaks, medium	400	5	240	16-20
2 beefsteaks, well done	400	5	240	20-23
2 pork fillets	350	5	240	19-23
2 pork chops	400	5	240	20-23
2 veal steaks	700	5	240	19-22
4 lamb cutlets	700	5	240	15-18
4 grill sausages	400	5	240	9-14
2 slices of meat	400	5	240	9-13
1 chicken, halved	1400	3	240-250	28-33(1.side) 23-28(2.side.)
Fish				
Salmon fillets	400	4	240	19-22
Fish in aluminium foil	500	4	230	10-13
Toast				
4 slices of white bread	200	5	240	1,5-3
2 slices of whole meal	200	5	240	2-3
Toast sandwich	600	5	240	4-7
Meat/poultry				
Chicken	1000	3	180-200	60-70
Pork roast	1500	3	160-180	90-120
Pork scrag	1500	3	160-180	100-180
Pork knuckle	1000	3	160-180	120-160
Roast beef/ beef fillet	1500	3	190-200	40-80

TECHNICAL INFORMATION

Model	PRSO108
Voltage rating	AC220-240V~ 50Hz
Total power	2800W
Top element	800W
Grill element	1000W
Bottom element	1000W
Circular element	1800W
fan	●