

Sales Code: FJ319

Description: Series 2 High Rise Mixer No Waste

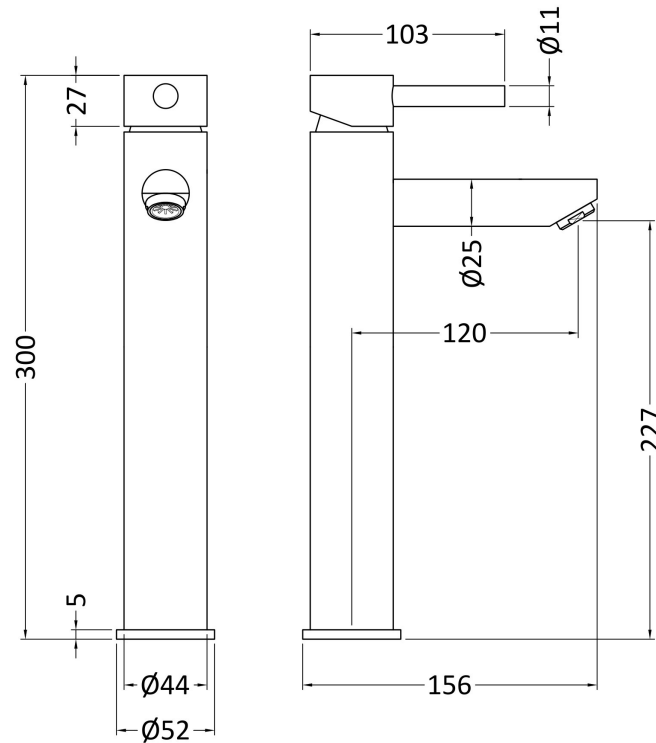

Product Dimensions

Height (mm):	300
Width (mm):	52
Depth (mm):	156
Length (mm):	
Nett Weight (kg):	1.3

Packaging Dimensions

Height (mm):	149
Width (mm):	54
Depth (mm):	315
Gross Weight (kg):	1.5

Packaging Data

Box Colour:	White Cardboard Box
Box Qty:	1
Label Size:	100 x 50
Label Colour:	White Label
Label Qty:	2

Outer Box Dimensions (If Applicable)

Height (mm):	375
Width (mm):	360
Depth (mm):	360
Length (mm):	
Gross Weight (kg):	15
Barcode:	5055146195269

Product Details

Country of Origin:	China
Fitting Instruction:	No
Product Material:	Brass
Control Type:	Manual
Waste Included:	Waste Not Included
Waste Type:	Not Applicable
WRAS Approval: No	Approval No: N/A
Valve/Cartridge Type:	Single Lever Cartridge
Colour/Finish:	Chrome
Mount Type:	Deck
Operating Pressure (bar):	0.2

Flow Rates: (Litres Per Min)	0.1 bar: 4	0.5 bar: 6,6	1 bar: 9,5	2 bar: 11	3 bar: 13,5
Pipe Size:	15 mm (1/2" Bsp)				
Pipe Centres:	N/A				