

monsoon Universal Twin Pumps U1.5, U2.0, U3.0, U4.0

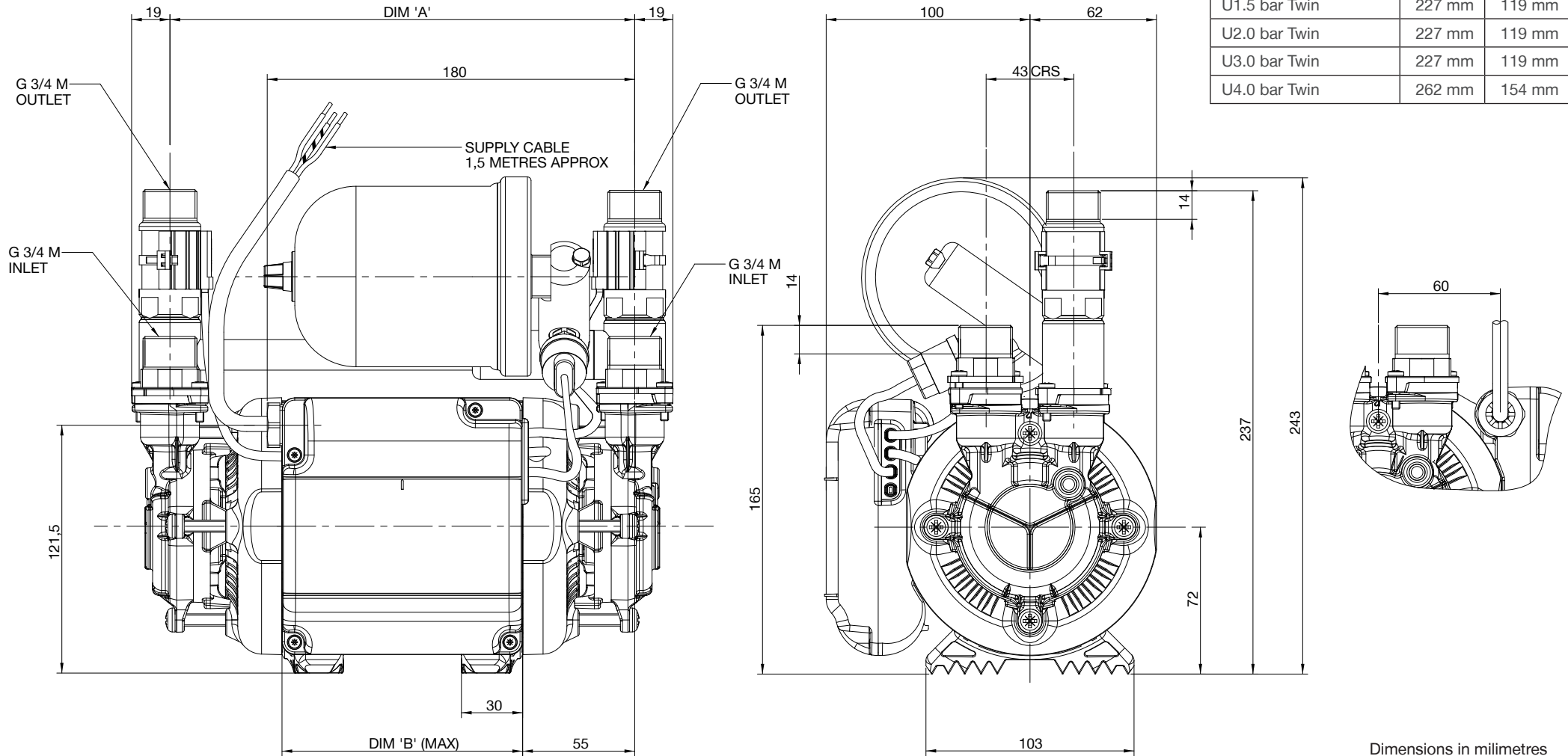

For further advice on selecting the correct pump call
or e-mail info@stpumps.co.uk

Issue 3015/1

Stuart Turner Ltd own the copyright within this document. The document may be printed for personal use only. The document must not be altered, reproduced or utilised in any way without written permission from Stuart Turner Ltd, Henley-on-Thames, Oxfordshire, RG9 2AD, England.

Stuart Turner Ltd reserve the right to amend the document or product specifications in line with it's policy of continuous development.

pumpassist
HELPLINE +44 (0) 844 98 000 97