

# GRAB 450 B



## Specification

Contemporary or Traditional:	Contemporary
Main Construction Material:	Aluminium
Connection Inlet:	N/A
Connection Outlet:	N/A
Mounting Type:	Wall Mounted
Adjustable Brackets:	No

### Features:

- Non corrosive aluminium construction
- 190kg max. user weight
- 1 year guarantee

### Product Certifications:

### Variant SKUs:

- GRAB 450 SS
- GRAB 450 G
- GRAB 450 W
- 
- 

For more products, visit our website:  
<http://www.bristan.com>



### Dimensions (measurements in mm)

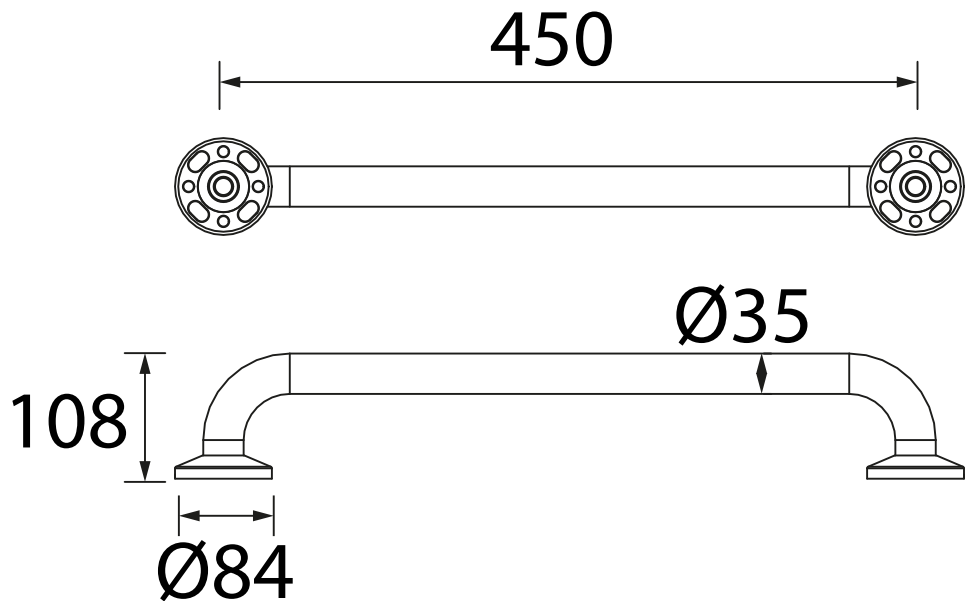

TECHNICAL  
DATA  
SHEET



BRISTAN

D2