



TECHNICAL SPECIFICATION

PDT-000047

3-in-1 Instant hot water kitchen tap - Chrome Finish



General Information

Standards 1	BS EN 200:2008
Construction Material	Brass
Installation type	Deck Mounted
Colour / Finish	Polished Chrome
Certification	WRAS
WRAS No:	Pending

Specification

Waste Included	No
Tap Tails Included	Yes
Style	Contemporary
Minimum Working Pressure	1
Maximum Working Pressure	3
Cartridge Type	35mm
Thermostat Cartridge Type	n/a
Flow Type	Tri Flow
Number of Tap Holes Required:	1
Handle Type	Lever
Swivel Spout:	Yes
Inlet Connection:	1/2" BSP Flexible Tails
Supply:	Suitable for all plumbing systems, preferably balanced
Tap Hole Diameter:	35mm
Type	Boiler Taps
Child Lock	Spring lock mechanism
Hot Water Dispenser Handle	Left side
Standard Hot and Cold Water Handle	Right Side
Height (mm):	358
Width (mm):	160
Length / Depth (mm):	235
SKU CAT No:	3
Category:	Kitchens
Sub Category:	Hot Water Taps
Product Weight (KG):	1.6
Carton Quantity (Pcs):	10
EAN:	5010000047009

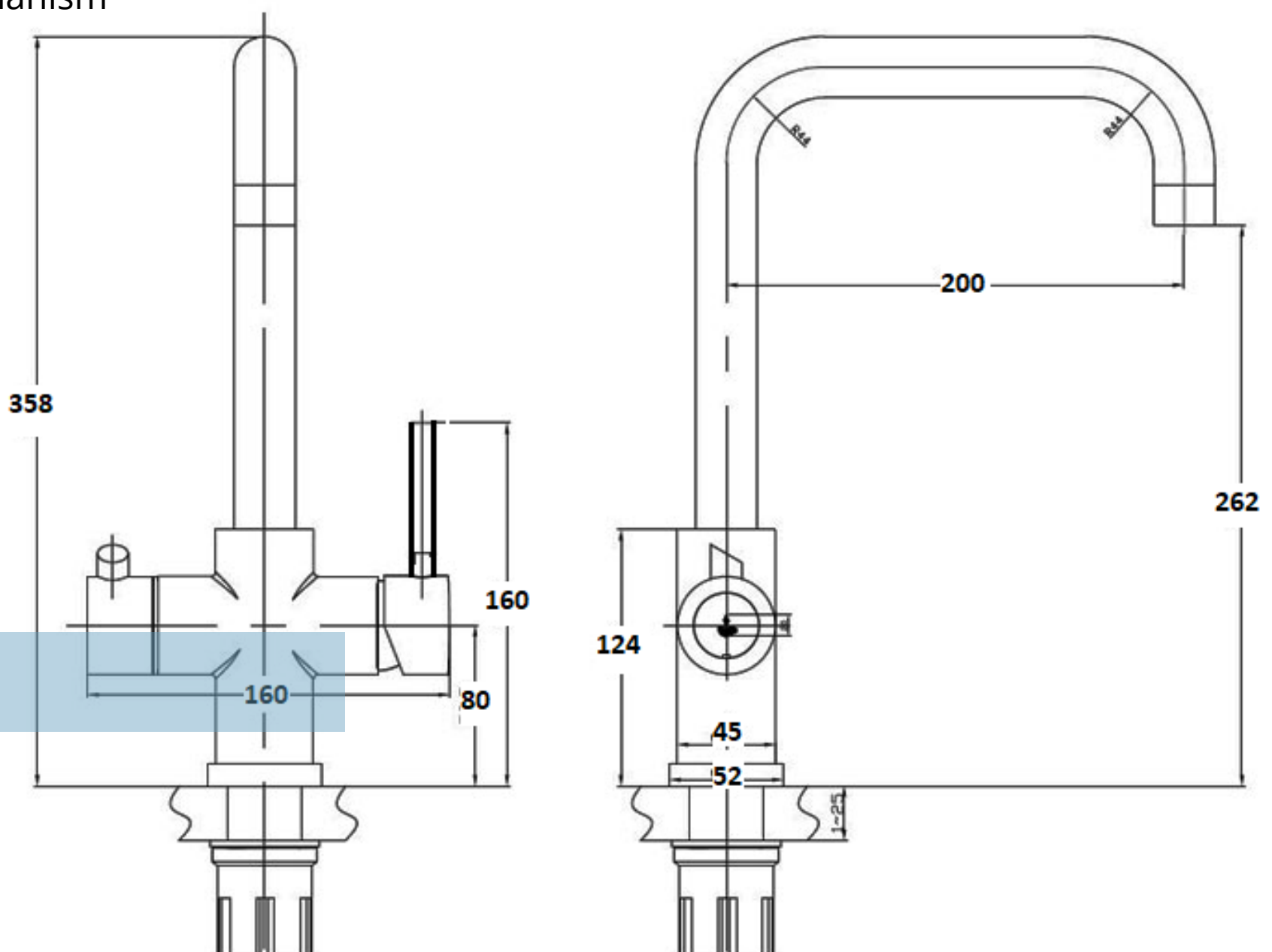

Flow Rates

Litres Per Minute

0.2bar	0.5bar	1bar	2bar	3bar
3.8	6	7.2	8	9.2

T: 01724 847397 or E: SALES@ELLSI.CO.UK