



Sandringham 21 Countertop Washbasin 50cm 2 Taphole

Illustrated

- E8953** Sandringham 21 countertop washbasin 50cm, 2 tapholes with overflow, no chainstay hole
- B9865** Sandringham 21 Washbasin Pillar Taps
- S8800** Waste, 1 1/4in plastic waste with bead chain and plug, 80mm slotted tail, bolt stay
- S8920** Trap 1 1/4in plastic resealing bottle, 75mm seal

Configuration options

- B9875** Sandringham 21 washbasin pillar taps, crosshead handles
- B9881** Sandringham 21 washbasin pillar taps, lever handles
- S8735** Waste 1 1/4in brass anti theft waste with chain and captive plug, 80mm slotted tail, bolt stay
- A5900** TMV Thermostatic mixing valve 15mm
- S8910** Trap 1 1/4in plastic bottle, 75mm seal

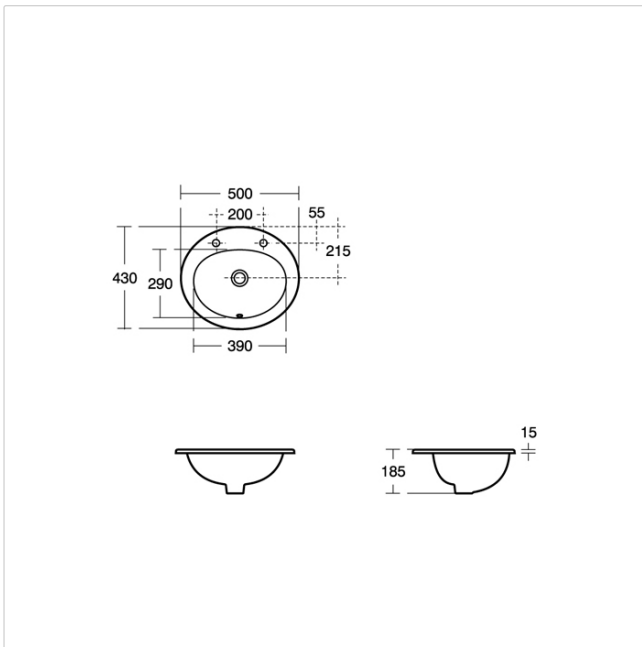

Material

Vitreous China

Weights

- E8953 5.8KG
- B9865 0.972KG
- S8800 0.08KG
- S8920 2KG

Colours

White (01)

Special Notes

Self-rimming for drop-in installation as per template supplied and joint sealed with waterproof sealant (not supplied).

Frequently used applications

- | | |
|--------------------|----------------|
| Education | Factory |
| Hotels | Office |
| Public Building | Pubs and Clubs |
| Residential | Retail |
| Sports and Leisure | |

