



Sandringham 21 Sink Mixer 2 Hole Dualflow Swivel Spout, Crosshead Handles

Illustrated

B9880 Sandringham sink filler 2 taphole dualflow swivel spout, crosshead handles

Configuration options

Weights

B9880 2.495KG

Colours

Chromium plated (AA)

Special Notes

Suitable for balanced/unbalanced supplies high or low pressure. Inlets with flexible hoses and connections for 15mm copper tails. Consideration should be given to safe hot water delivery and the use of an appropriate temperature reduction device see S7435AA. Water saving can be achieved by use of a flow regulators such as L6935NU to deliver maximum of 4 Litres per minute.

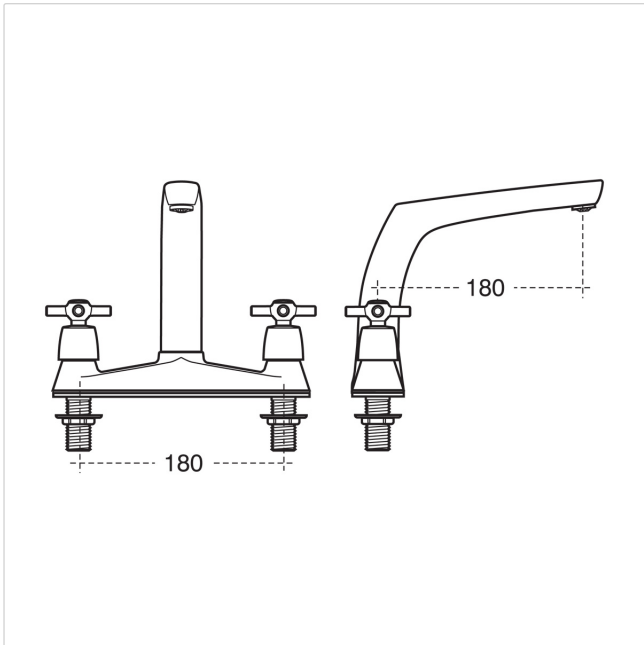

Frequently used applications

Education	Factory
General Healthcare	Hotels
Office	Public Building
Pubs and Clubs	Residential
Retail	Social Housing
Sports and Leisure	Student Accommodation

*Armitage
Shanks*

Tel: 0870 122 8822
Fax: 0870 122 8282
Email: info@idealspec.co.uk
Web: www.idealspec.co.uk

Ideal Standard (UK) Ltd. makes every effort to ensure that the information provided on its website is accurate. However, we cannot guarantee this, and accept no liability for any information or advice given via its website.

Powered by
Ideal Spec

Date created:24/02/2013