

Space Collection
Fitting Instructions

Waters

Baths of Ashbourne

Foreword...

Thank you for purchasing a Waters Space shower bath, It will give you many years of peaceful relaxation, and we hope you don't just have a bath, you Love your bath...



Prior to installat... Seb Waters

Please ensure that your plumbing system is adequate and that you have sufficient space to complete the installation.

Please Note:

We recommend that you employ a suitably qualified plumbing professional to complete the installation of your new bath. We can not accept responsibility for poor or incorrect installation. Please keep these instructions in a safe place for future reference.

Step 1

Unpackaging...

Carefully open the box at the top, cutting the banding and taped seam. Do not insert a blade through the cardboard as this may damage the bath inside.

Remove the top cardboard sheet and corner inserts. Leaving the bath fully wrapped remove from the carton. Carefully unwrap all the shrink wrap and foam protection from around the bath. Remove all packaging from the working area although you may find a cardboard sheet useful as installation template.

Leave the internal cellophane sheet inside the bath until installation is complete to avoid any accidental damage

1,

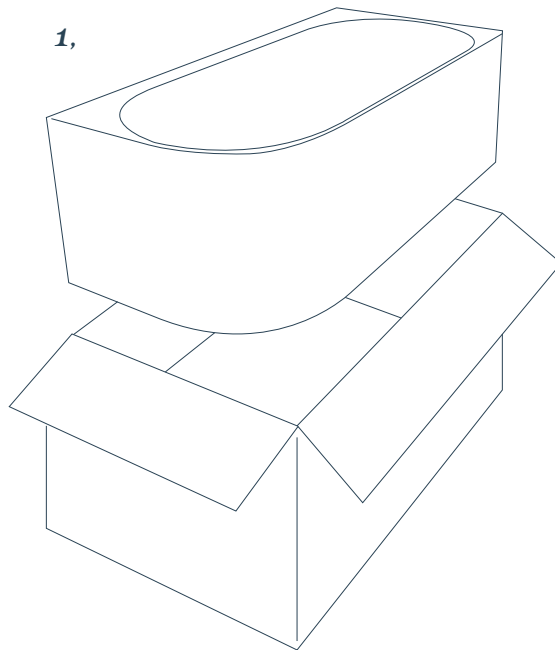

Step 2

Position...

Once unwrapped, carefully check the bath to ensure it is perfect condition before undertaking installation.

Please check you have allowed the correct floor void for your specific bath before installation.

Locate the bath in its intended position and draw around the lower outer edge and mark the waste location with a pencil. Access to the waste and any isolation valves should be considered.

3.

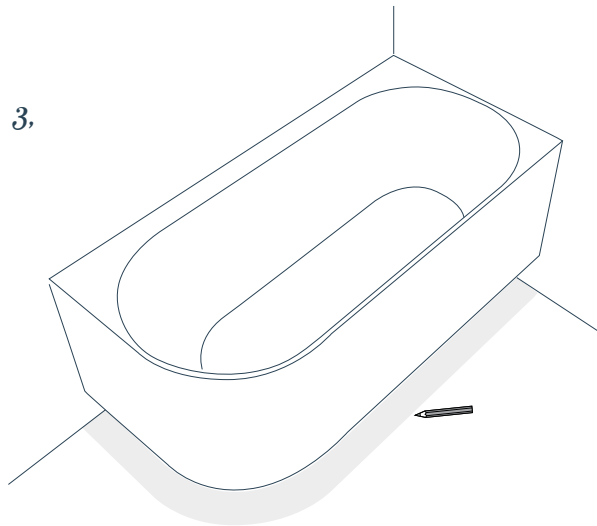

Step 3

Supporting...

To ensure the bath is adequately supported we recommend wall battens are fixed along the length and width of the supporting walls providing top edge support and maximum stability .

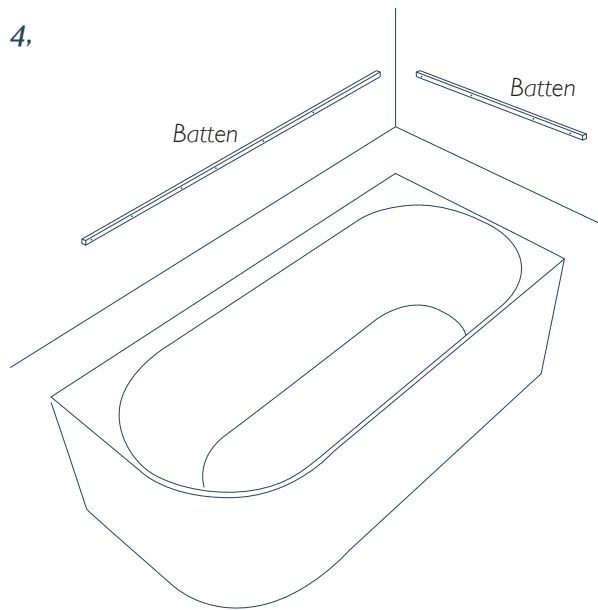

Due to the design and production methods of the Flow Bath there will be a small gap between the top ledge of the Bath and the wall, we recommend that the bath is fitted up to the bare wall and the tiling works should finish at the top ledge of the bath, The seal can be completed with a continuous bead of silicone sealant to complete the watertight seal required.

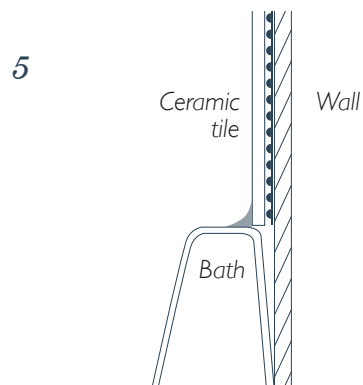

Step 4

Levelling...

With the bath in its intended position use a large spirit level to check that it is level on both the horizontal and vertical planes.

The bath can be adjusted by twisting the four threaded feet. Only if the bath is level will all the water drain to the waste outlet.

Ensure the bath stands evenly at least 1-2mm off the floor to allow for expansion and to create a positive fixing seal.

Once the bath is level, tighten the foot adjustment lock-nuts to ensure no further movement.

Ensure you allow for any variation of the floor surface and that the bath has been levelled in its intended final location.

6,

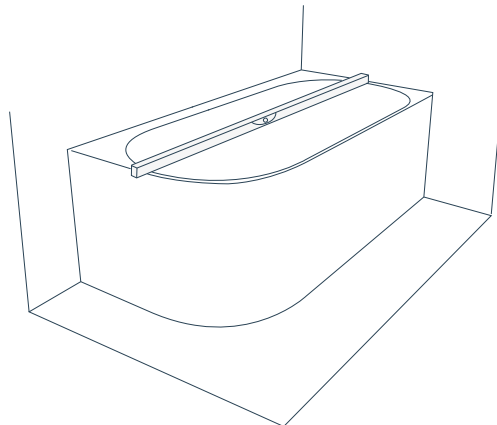
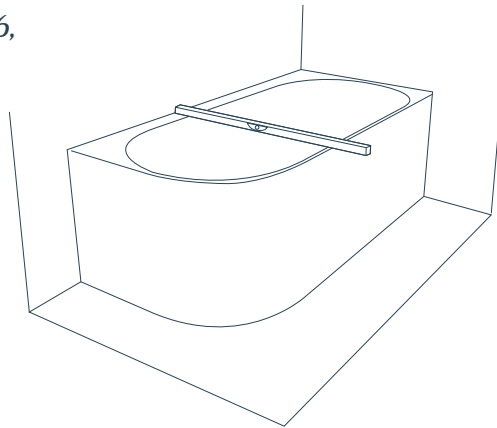

Step 5

Waste...

Once the pipe work is completed and ready to receive the bath we recommend raising the bath on a number of blocks – this will allow working access for you to connect the waste to the underside of the bath.

Once tight add silicone adhesive to the base of each foot, remove the blocks and lower the bath into position, ensuring that the pipe work is not damaged.

7,

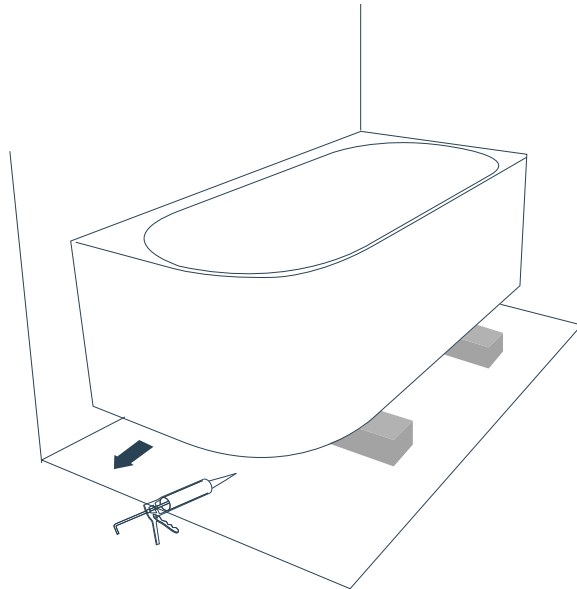

Remember you do not need to fit your bath directly over the soil pipe. It can be positioned in close proximity with the use of a flexible waste pipe.

Step 6

Fixing...

Before final fixing check that the bath is level and connected to the plumbing system, by adding water and ensuring it drains away adequately leaving no puddles and that there are no leaks.

Once checked, half fill the bath to ballast it before securing it to the floor.

Apply silicone adhesive evenly between the base of the bath and the floor filling the 1-2mm gap.

To ensure the best result leave the water in the bath 10 – 12 hours or overnight while the silicone adhesive sets.

8,

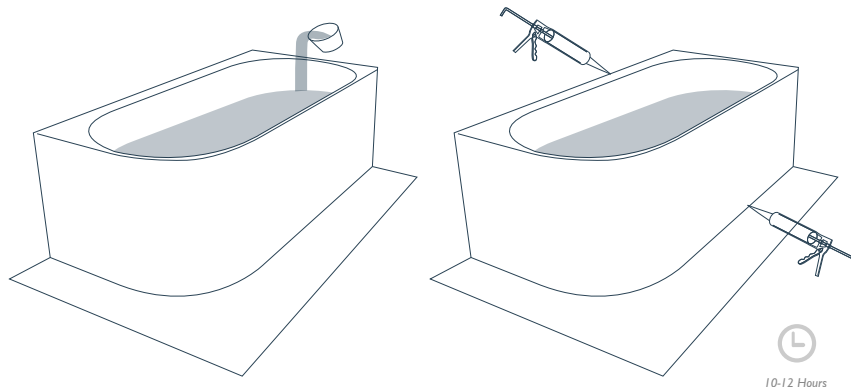

Care Info

To clean your bath use a soft damp cloth and warm soapy water, household bathroom cleaners may also be used – but you should check their suitability before proceeding.

Do not use abrasive scrubbing materials or harsh chemical cleaners as these may permanently damage the bath's surface and finish.

Warning

Solvents such as paint stripper or nail varnish remover will damage the bath.

Warranty

& Guarantees

To demonstrate our confidence in the quality and reliability our products, all Waters Baths of Ashbourne Baths are guaranteed to be free of defects in material and workmanship during use by the original purchaser for a period of 20 years and bespoke paint finishes 2 years from date of purchase.

Subject to the terms contained herein, Waters Baths will, at its discretion, repair or replace any defective product, or refund the purchase price. In no event shall the liability under this warranty exceed the original purchase price of the product. Waste kits and accessories are not covered under this guarantee.

Exceptions.

The guarantee does not extend to:

- *Damage caused by cleaning, maintenance, or installation performed other than strictly in accordance with the information contained in the fitting Instructions;*
- *Damage caused by the use of strong chemicals in cleaning;*
- *Damage caused by the use of strong dyes or colourants*
- *Scratching, or staining of the finish over time due to water impurities or atmospheric conditions;*
- *Damage caused by extreme temperature conditions;*
- *Damage due to installation error, product neglect, misuse, or abuse, accident, or negligence, whether caused by the purchaser, a contractor, or a service provider, or any other cause beyond the sellers control.*

Replacement.

Waters Baths of Ashbourne will replace or repair the installed defective products subject to the following conditions:

- *Any claim is made in writing to our office within 10 days of the problem being apparent;*
- *Any claim is by the original purchaser, this guarantee is not transferable;*
- *The product has been used in the manner that it was intended, this protection does not apply to any products that have been misused in any way;*
- *The product must have been installed and cared for in line with our Installation and care instructions.*

(See Installation and care Instructions for proper cleaning, maintenance, and installation information.)

Making a Claim.

To file a claim, contact Waters Baths of Ashbourne through your supplying retailer or by writing to us at Waters Baths of Ashbourne, Long Lane, Dalbury Lees, Ashbourne, Derbyshire, DE6 5BG. Please be sure to provide all relevant information along with supporting images regarding your claim, including a complete description of the problem, the model name, size and any bespoke finish applied to the product, along with the date and place of purchase. Also include your original invoice. In order to assess any claim, we may have to inspect the product as installed before removal and must be provided with access to the product upon request.

Except as provided herein, seller makes no guarantee of any kind, express or implied, with respect to the product, its merchantability, or fitness for a particular purpose. Seller shall not be responsible for any indirect, incidental, or consequential damages resulting from the delivery, installation, or use of the product.

Before installing the bath please read our installation and care instructions. If you have any questions please contact your supplying dealer or us directly on +44 (0) 1332 824166 or via email on info@watersbaths.co.uk

Tech Info

Bath Specification...

Space collection...

Using Lucite acrylic, Waters Baths of Ashbourne are proud to offer the Space bath collection designed to meet the demands of the most discerning customers.

Ebb

1660mm



Sizes available:

1660 x 800 x 580mm
- LxVxH

Weights:

1660mm - Gross 68kg - Net 60kg

Available in right & left hand options

Fill information: 1660

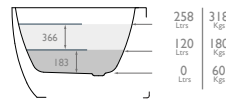

Filler options:

OWF, FSBF, WF, BF, CF.

Please note:

Minimum installation void required for trap and waste is 0mm below floor level.

Flow

1660mm



Sizes available:

1660 x 800 x 580mm
- LxVxH

Weights:

1660mm - Gross 68kg - Net 60kg

Available in right & left hand options

Fill information: 1660



Filler options:

OWF, FSBF, WF, BF, CF.

Please note:

Minimum installation void required for trap and waste is 0mm below floor level.

Coast

1700mm



Sizes available:

1700 x 750 x 580mm
- LxVxH

Weights:

1700mm - Gross 66kg - Net 58kg

Available in right & left hand options

Fill information: 1660

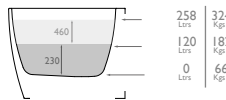

Filler options:

OWF, FSBF, WF, BF, CF.

Please note:

Minimum installation void required for trap and waste is 0mm below floor level.

WB7

Folding screen

Size:

900 x 1500mm (8mm thick glass)
- L x H x W

Weights:

Gross 29kg - Net 27kg

Handed screen - left hand shown

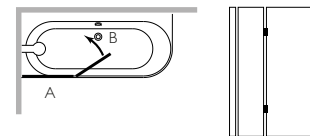

A - Fixed Panel

B = Radius of Screen Swing = 400mm

WB2

Bath screen

Size:

800 x 1500mm (6mm thick glass)
- L x H x W

Weights:

Gross 20kg - Net 18kg

Reversible screen

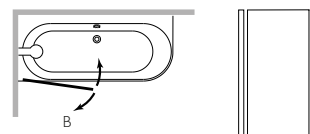

B = Moving panel

**Bath overflow fillers
also available...**



www.watersbaths.co.uk

Lawns Farm, Long Lane, Dalbury Lees, Ashbourne, Derbyshire, DE6 5BG.
t: 01332 824166 - e: info@watersbaths.co.uk