

TS1503 VALVE DIMENSIONS

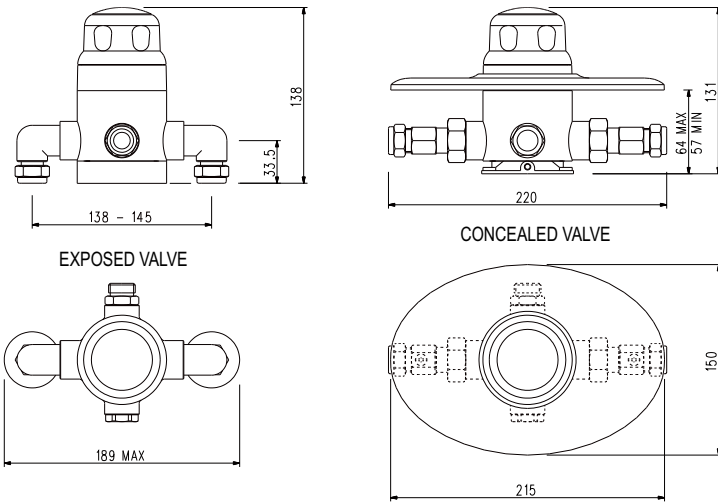

Dimensions in mm

SERVICE POLICY

In the event of a complaint occurring with this valve or any of our products, the following procedure should be adopted.

*Telephone the Customer Services Department on **0844 701 6273**

*Ensure that you have available the following information: The model type, date of purchase and the valve serial number.

*The Service Department will attempt to diagnose the cause of the fault and advise the required action necessary to rectify the fault.

*If a service call from a Service Agent is required either due to the fault being unable to be diagnosed over the telephone you will be sent a Site Visit Request Form for your completion and return so that a service call can be actioned.

* For products that are outside the 12 month warranty period a fixed fee payment will be charged. This fee includes all parts used to rectify the complaint. The cost and acceptable methods of payment will be advised both over the telephone and the on Site Visit Request Form.

* Payment and the completed form must be received by us before a service call can be actioned.

* For products that are still within the 12 month warranty period and no pre-payment is necessary. However, the completed Site Visit Request Form must be returned to use before a service call can be actioned.

* If the service call reveals that the reported fault is not product related then a fixed charge will be levied to cover engineer costs. This cost be advised both over the telephone and the on Site Visit Request Form. Additional costs will be levied for parts used to rectify a non-product related fault.

Customer Care ☎ 0844 7016273

CUSTOMER REFERENCE DATA

Model Type:
 Date of purchase:
 Installer: Tel No:
 Serial No:

BRISTAN

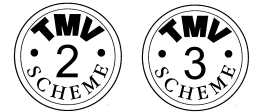

TS1503 OPAC SHOWER CONTROL

TEMPERATURE STABILISED THERMOSTATIC SHOWER CONTROL

Please leave with the user

INSTALLATION MAINTENANCE AND OPERATING GUIDE

FOR CONCEALED AND EXPOSED INSTALLATION MODELS

OUR QUALITY CONTROL PROCEDURES ENDEAVOUR TO ENSURE THIS PACK IS COMPLETE HOWEVER, IF YOU FIND ANY PARTS MISSING OR REQUIRE TECHNICAL INFORMATION, PLEASE CONTACT THE MANUFACTURER:-

Bristan Group Ltd
 Birch Coppice Business Park
 Dordon
 Tamworth
 Staffordshire
 B78 1SG
 T: 0844 7016274
 E: customercare@bristan.com

CONTENTS

- Section One
- Section Two
- Section Three
- Section Four
- Section Five
- Section Six
- Section Seven
- Back Cover

- Introduction
- Installation Requirements
- Fitting the Valve
- Parts List & Assembly Sequence
- User Instructions
- Technical Data
- Diagnostic Flow Chart
- Valve Dimensions, Service Policy

PAGE

- 1.
- 2.
- 4.
- 5-6.
- 7.
- 9.
- 10.

SECTION ONE INTRODUCTION

Please read these instructions carefully, and ensure that the shower valve is installed to local Water Authority regulations. If in doubt, contact a plumber or the Secretary, Institute of Plumbing, 64, Station Lane, Hornchurch, Essex Rm21 6NB. Telephone: 01708-472791.

This valve is thermostatic; it mixes hot and cold water to supply a shower. It automatically adjusts the mix in response to incoming temperature to ensure that the temperature remains substantially constant.

It accepts 15mm o.d hot and cold pipes. The temperature can be controlled but the flow rate can only be adjusted on the concealed models.

IMPORTANT: The plating on the valve and accessories is EASILY DAMAGED. Ensure any spanners you use on nuts have smooth, clean faces and are of the correct size. Apply a layer of strong adhesive tape to the spanner faces if you are in doubt. Always handle tools and the

Immediately after installation, COVER UP the valve and accessories to avoid accidental damage from work being done elsewhere in the room. Plaster, grout, sealants and dust will cause permanent stains or scratches. Wrap a clean sheet, or better still, secure bubble pack around the items using adhesive tape to protect them against knocks and contamination.

PARTS & SERVICE

Spare parts for your purchased valve are available. If you require technical advice or a service call, contact the Customer Service Department on 0844 701 6273.

SECTION SEVEN

DIAGNOSTIC FLOW CHART

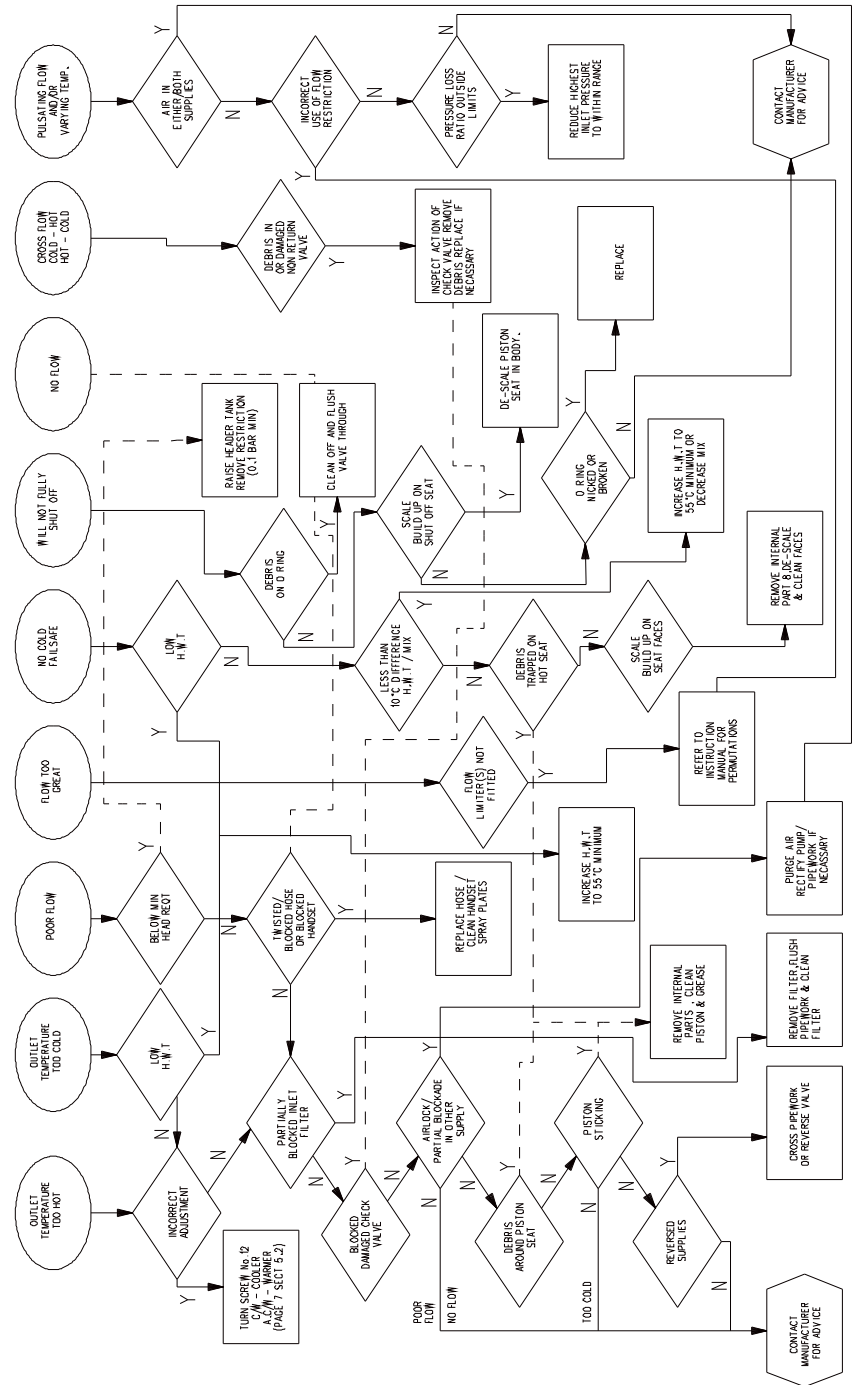

SECTION SIX TECHNICAL DATA

INLETS: 15mm compression with swivel elbows on exposed models, 15mm isolating valves on concealed valves.

OUTLETS: ½”B.S.P male iron/15mm compression adaptor.

WEIGHT: 2.3 kg

MINIMUM PRESSURE DROP THROUGH FITTING FOR CORRECT MIXING:
0.1 bar (1 metre head)

MAXIMUM PRESSURE DROP THROUGH FITTING FOR CORRECT MIXING:
5.0 bar (50 metre head)

MAXIMUM STATIC PRESSURE TO BE APPLIED TO FITTING:
10.0 bar (100 metre head)

TEMPERATURE STABILITY WITH NORMAL VARIATION OF SUPPLY TEMPERATURE AND PRESSURES:
+/-2 Degrees Celcius from set temperature.

FACTORY SET MAXIMUM BLEND TEMPERATURE:
43 Degrees Celcius (can be re-set on site between 30 and 50 Deg. C)

MINIMUM TEMPERATURE DIFFERENTIAL BETWEEN HOT SUPPLY AND OUTLET TEMPERATURE:
10 Degrees Celcius (eg Shower Temperature 43 Deg. C : Minimum Hot Supply 54 Deg. C)

MAXIMUM HOT SUPPLY TEMPERATURE: 80 Degrees Celcius.

PERFORMANCE: (Open outlet only. Does not allow for losses through pipes or fittings)

Pressure drop (bar)	0.1	0.2	0.4	0.6	0.8	1.0	1.5	2.0	3.0	4.0	5.0
Flow rate	8	12	17	22	26	29	36	42	52	60	66

Flow rates in litre/min. On equal pressure drops.

SECTION TWO INSTALLATION REQUIREMENTS

2.1 To ensure the correct operation of this shower mixer valve it is important to fully understand your site installation.

This thermostatic valve will suit supplies of:

**HIGH PRESSURE
LOW PRESSURE
MAINS PRESSURE
PUMPED PRESSURE
UNEQUAL PRESSURE
GRAVITY PRESSURE**

Depending upon your hot and cold water supply system and/or pressure you may need to make alterations and/or fit flow limiters to the valve before installing it.

Table (fig 2.1) gives guidance on which, if any, limiters or adjustments are to be made to the valve. Failure to follow these guidelines may result in poor performance.

2.2 The valve is supplied with the hot inlet on the left and cold inlet on the right as viewed from the front. The outlet is then facing downwards. The hot supply must be connected to the inlet port 'H'.

The orientation of each inlet can be changed to top, bottom or rear. (see section 2.8).

2.3 This installation should meet the requirements of the Water Regulations. If in doubt contact your local water authority for advice or a registered member of the Institute of Plumbers.

Telephone: 01708 472791 for a list of your nearest qualified plumbers.

2.4 Before commencing it is advisable to install isolating valves on both hot and cold supplies for flushing out and servicing purposes, this is only needed on exposed valves due to the fact that concealed valves are supplied with them.

2.5 We recommend fitting strainers to ensure no debris enters the mixing valve. Isolating valves which incorporate strainers are ideal for this purpose, on concealed valves it is advisable to fit the filters provided.

2.6 A simple way of flushing both supply pipes is to fit the outlet adaptor (26) to both pipes and secure with compression nut (32) and olive (31), fit hose to the adaptor and flush out pipes to waste.

2.7 Enclosed in your packaging are 2 filters (37 or 51). These should be fitted to each inlet as shown in fig. 2.2. However, for institutional installations we recommend the fitting 'Y' type strainers instead of these filters because of the more sensitive environment these valves will be expected to operate in.

INLET POSITIONS

2.8 Before mounting the valve to the wall, the position for PIPEWORK should be decided. Three inlet positions, Top, Bottom and Rear are available, simply by rotating the elbows in the valve body. Set the elbows to the required orientation, (Top, Rear or Bottom) and then check the inlet centre distance.

With the elbows screwed fully against the valve body it is possible to unscrew the elbows a maximum of 1 1/2 turns to allow for tolerance.

2.9 If your inlet pipes are already in place and are 'cold on the left, hot on the right' you can exchange the outlet fitting with the blanking plug. This will allow you to rotate the valve through 180 degrees to suit your existing pipework. You must ensure that your hot supply is connected to the inlet port marked 'H'. If you do need to turn the valve around, you will then need to remove the knob and sleeve assembly and turn these through 180 degrees, so that they are again orientated correctly (ie.. 'OFF' and Indicator Arrow at the top).

COLD SUPPLY	HOT SUPPLY	FIT TO ELBOWS		COMMENTS
		COLD	HOT	
0.1 TO 1 BAR (1 TO 10 MTR HEAD)	0.1 TO 1 BAR (1 TO 10 MTR HEAD)	NOTHING	NOTHING	MAX RATIO OF HOT-COLD PRESSURE 1:5 / 5:1
1 TO 5 BAR (10 - 50 MTR HEAD)	1 TO 5 BAR (10 - 50 MTR HEAD)	GREEN 7 LITRE LIMITER	YELLOW 5 LITRE LIMITER	THIS ARRANGEMENT WILL ALSO SUIT PUMPED SYSTEMS #
MAINS (1.5 TO 10 BAR)	GRAVITY 0.1 TO 0.2 BAR (1 TO 2 MTR HEAD)	WHITE ORIFICE (No washer required)	NOTHING	
	GRAVITY 0.2 TO 0.5 (2 TO 5 MTR HEAD)	GREEN 7 LITRE LIMITER	NOTHING	
	GRAVITY 0.5 BAR+ (5 MTR HEAD)	GREEN 7 LITRE LIMITER	YELLOW 5 LITRE LIMITER	
	UNVENTED HOT WATER STORAGE SYSTEM (SHOWER COIL)			
	COMBI-BOILER INSTANTANEOUS GAS WATER HEATER	GREEN 7 LITRE LIMITER	YELLOW 5 LITRE * LIMITER	ADJUST BOTTOM CAP ** (1/2 turn anti-clockwise)
	ELECTRIC UNVENTED *** INSTANTANEOUS HEATED	YELLOW 5 LITRE LIMITER	NOTHING	ADJUST BOTTOM CAP** (1/2 turn anti-clockwise)
	ANY VENTED (OPEN OUTLET) HEATER, GAS OR ELECTRIC, EG.. 'NORMAL' ELECTRIC SHOWER	DO NOT USE WITH MIXER VALVE - THIS WOULD BE EXTREMELY DANGEROUS		

This table shows (fig 2.1) Flow limiter requirements and valve adjustments for various hot/cold supplies.

Flow limiters are fitted and will be required to be removed when installed in low pressure applications below 1 bar. To remove: unscrew retaining ring and remove limiter and washer. Re-fit elbows back into the body.

* With certain permutations of combi-boiler hot supply and cold supply, it must not be necessary to fit the yellow 5 litre flow limiter.

** The bottom cap is factory set at 3/4 turn from the fully closed position. Only adjust if instructed to do so in the table 2.1 or when fitting a replacement cartridge assembly. (See section 5)

*** IMPORTANT. It is a requirement of Instantaneous Electric Water Heaters that a stable flow of water passes through the heater. This requirement can be satisfied by using a Flow Stabiliser in the supply to the heater. It should be adjusted to give a flow temperature of 45 - 50°C from the heater.

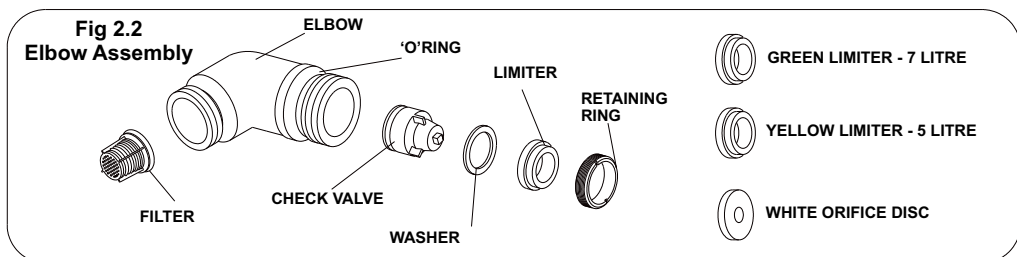

* Remove head as an assembly of parts. Place aside piston and distributor assembly (22). Do not dismantle this assembly.

* Unscrew the half cartridge (17) (Note: Do not grip the half cartridge in vice jaws or wrench jaws. You can release the half cartridge by inserting a flat tool (flat file) and a spanner on the hexagon part of the head driving one against the other - the half cartridge is a standard right hand thread.

* Remove circlip (5) and push out spindle assembly (10-16).

* Remove all O rings and washers from spindle assembly, unscrew spindle (left hand thread) and remove adjusting screw (16) from the spindle housing (13), noting approximate number of turns to release.

5.4 CLEANING

* Soak all metal parts in descalent, wash off in clean water.

* Examine all seals and replace if necessary, (a maintenance kit is available which contains all seals from your local stockist or manufacturer).

* Use silicone based grease on all seals (light smear only), and on the thread of the spindle (10) and spindle housing (13).

5.5 RE-ASSEMBLY

* Add P.T.F.E washer (12) to spindle (10) from the splined end, then the O ring (11). The spindle is then screwed into the spindle housing (13). Locate this new assembly into the head (6) and fit the circlip (5). Please note that the circlip does not locate on the groove immediately beneath the splines but locates on the next one down towards the threaded end.

* Take the head assembly and screw onto half cartridge (17).

* Place thermostat (21) into piston and distributor assembly (22) and place return spring (24) into the recess in the bottom of the piston and distributor assembly (use a dab of grease to retain it in place whilst installing into the valve).

* Offer the piston assembly up to the head assembly ensuring that the thermostat (21) is located in the recess in the adjustment screw.

* Screw the whole assembly into the valve body (25) and tighten. Do not adjust the bottom cap (36) unless you are installing a new cartridge. If this is the case, screw the bottom cap fully clockwise until it stops, then unscrew anti-clockwise 3/4 turn only. Then refer to table 2.2 on page 3 to see if any further adjustments are required for your particular system.

* Replace sleeve (4), retaining ring (3) and knob/ lever and refer to maximum temperature setting on page 7 section 5.2.

* After re-setting your desired maximum outlet temperature replace O ring (9), O ring (7) and spindle screw (8) and finally replace printed indice.

SECTION FIVE USER INSTRUCTIONS

5.1 Operation Temperature

Turn the control knob/lever anti-clockwise, almost immediately full flow will be achieved. The temperature is controlled progressively warmer as you continue to rotate the knob/lever. The maximum temperature is factory set at 43 degrees celcius at the No.9 position (No.6 position on the lever). However, this may require adjusting due to your site installation.

5.2 Maximum Temperature Setting

The maximum blend temperature should be limited to ensure that no undesirable temperature is obtained. If adjustment is necessary adopt the following procedure:

> Removed the printed indice from the knob/lever' (it is not necessary to remove the knob/lever.)

> Turn the control knob/lever anti-clockwise to the maximum position.

> Remove the spindle screw (8), water seepage through the end of the spindle is normal.

> Using a thin bladed screwdriver through the spindle (10) turn the adjusting screw (16) to alter the maximum temperature.

*** Turn anti-clockwise for a warmer temperature**

*** Turn clockwise for a cooler temperature**

> When the desired maximum temperature is obtained, replace spindle screw (80) and indice.

INSTALLERS NOTE

THIS PROCEDURE SHOULD BE DEMONSTRATED TO THE END USER

5.3 Servicing/Maintenance

> If your thermostatic mixer fails to operate correctly it could be the result of an incorrect installation. Please refer to the installation and site requirements.

> If the valve has operated correctly for some time, but no longer performs acceptably, you may find it useful to firstly refer to the fault diagnosis flow chart on page 10 of this booklet to identify the fault. (Please note that this fault flow chart is a general guide only).

> Should the valve require servicing the following procedure should be adopted:

* Isolate both hot and cold supplies.

* Prise out indice, remove spindle screw (8) and pull-off control knob/lever. Be sure to retain O seals (7) & (9).

* Remove the concealing plate (39) for concealed model. Remove retaining ring (3) by pulling off sleeve (4).

* Unscrew head (6) using spanner on large hexagon.

* Remove head as an assembly of parts. Place aside piston and distributor assembly (22). Do not dismantle this assembly.

SECTION THREE FITTING

3.0 EXPOSED MOUNTING

Please refer to section 2 (page) 2 to ensure the General Installation requirements are met.

Use the exposed backplate (41) as a template for the fixing holes.

Drill and plug wall to suit screws provided. Fit grubscrews (46) loosely to backplate and secure the backplate to the wall.

Locate the valve body to the wall and lock with grubscrew. Fit outlet adaptor (26) to valve exchange with outlet plug (29) for top outlet.

Connect inlet pipes to valve with compression fittings, please ensure the hot supply, disconnected to the inlet port 'H'.

4.0 CONCEALED FIXING

Please refer to section 2 (page 2) to ensure the General Installation requirements are met.

It is essential that when installing a concealed mixing valve, full access can be achieved for servicing purposes, isolating adaptors are fitted as standard on concealed models, these need to be fitted with the filters provided.

Rear access to the mixing valve is always preferred wherever possible (eg.. An airing cupboard or panel wall), as this removes the need to disturb any tiling or decorative features at the front of the valve. If this is not possible, remove access panel of 300mm square minimum, fitted to a simple wooden frame work could be installed to allow full access and removal of the valve if necessary. Such a panel could, for example, be tiled over and secured with mirror screws in each corner and the screw capped. Removal of a valve installed in this manner would mean disturbing only a few tiles.

Concealed valves are supplied with an isolating valve assembly. Before installation they need to be fitted to the valve and the relevant pipework.

The check valve has to be placed the correct way round inside the inlet adaptor, the Oring needs to be fitted on to the exterior of the inlet adaptor.

Fit the assembly inlet adaptors to the valves. Attach the isolating adaptor to the pipework. Using the filter as a seal, connect isolation adaptor to the valve assembly. The Allen key provided is used to open and close the isolating adaptor.

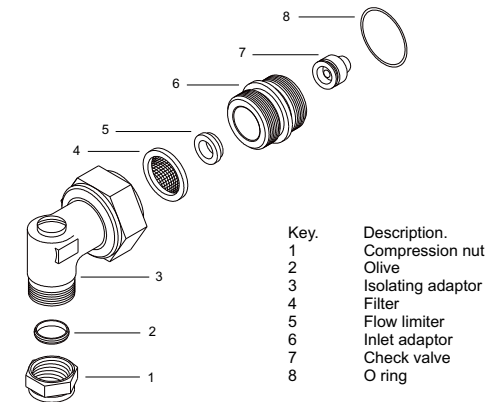

Once the valve is installed and tiling complete, ensuring both the inner seal (38) and outer seal (40) are affixed to the concealing surround (39) over the sleeve (7) firmly against the wall.

Important Notice

Flow limiters are now fitted to this thermostatic valve as a requirement of NHS model Engineering specification D08. Remove flow limiters when valve is installed in low pressure applications, below 1 Bar, before isolating adaptors are fitted.

SECTION FOUR PARTS LIST

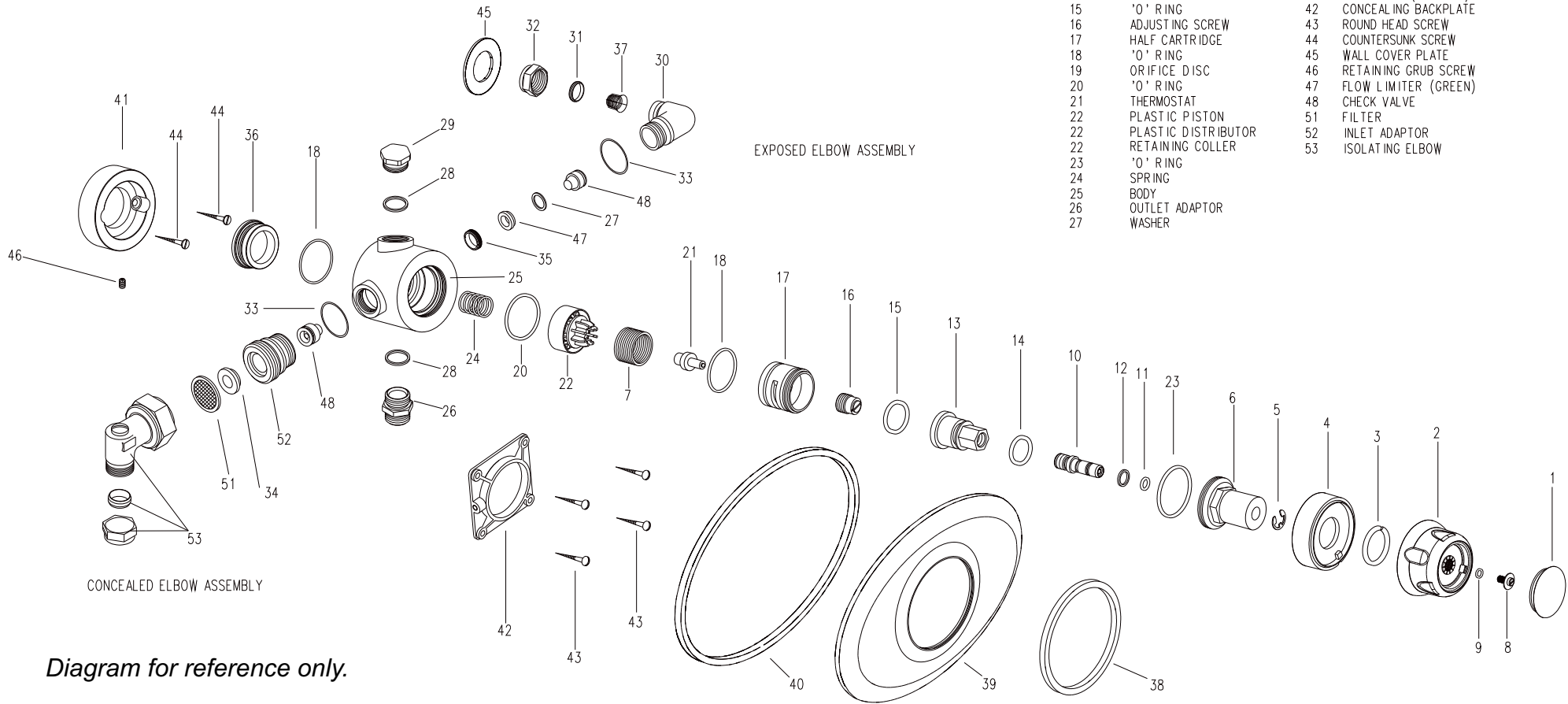

KEY No.	DESCRIPTION	KEY No.	DESCRIPTION
1	INDICE	28	'O' RING
2	TEMPERATURE KNOB	29	OUTLET PLUG
3	RETAINING RING	30	ELBOW
4	SLEEVE	31	COMPRESSION RING
5	CIRCLIP	32	COMPRESSION NUT
6	HEAD	33	'O' RING
7	SPRING (LARGE)	34	FLOW LIMITER (YELLOW)
8	SPINDLE SCREW	35	RETAINING RING
9	'O' RING	36	BOTTOM CAP
10	SPINDLE	37	FILTER
11	'O' RING	38	CONCEALING PLATE INNER SEAL
12	P.T.F.E. WASHER	39	CONCEALING PLATE
13	SPINDLE HOUSING	40	CONCEALING PLATE OUTER SEAL
14	'O' RING	41	BACKPLATE (EXPOSED)
15	'O' RING	42	CONCEALING BACKPLATE
16	ADJUSTING SCREW	43	ROUND HEAD SCREW
17	HALF CARTRIDGE	44	COUNTERSUNK SCREW
18	'O' RING	45	WALL COVER PLATE
19	ORIFICE DISC	46	RETAINING GRUB SCREW
20	'O' RING	47	FLOW LIMITER (GREEN)
21	THERMOSTAT	48	CHECK VALVE
22	PLASTIC PISTON	49	FILTER
22	PLASTIC DISTRIBUTOR	50	INLET ADAPTOR
22	RETAINING COLLER	51	ISOLATING ELBOW
23	'O' RING		
24	SPRING		
25	BODY		
26	OUTLET ADAPTOR		
27	WASHER		

Diagram for reference only.