



**INSTALLATION AND OPERATING INSTRUCTIONS
FOR THERMOSTATIC MIXING VALVES COMPLYING WITH
N.H.S. ESTATES MODEL ENGINEERING SPECIFICATION D08**

**THE VALVES COVERED IN THIS BOOKLET HAS BEEN TESTED AND APPROVED
TO N.H.S. ESTATES MODEL ENGINEERING SPECIFICATION D08**

**IT MAY PERFORM SATISFACTORILY OUTSIDE THE LIMITS SPECIFIED HOWEVER
IT WILL NOT BE COVERED BY THE TMV3 SCHEME**

TEMPERATURE STABILISED THERMOSTATIC SHOWER PANEL

TMV3 Designations of use :-

HP-SE High Pressure Shower Economy
LP-SE Low Pressure Shower Economy

NORMAL WORKING PRESSURE RANGE: Min. 0.5 Bar, Max. 5.0 Bar

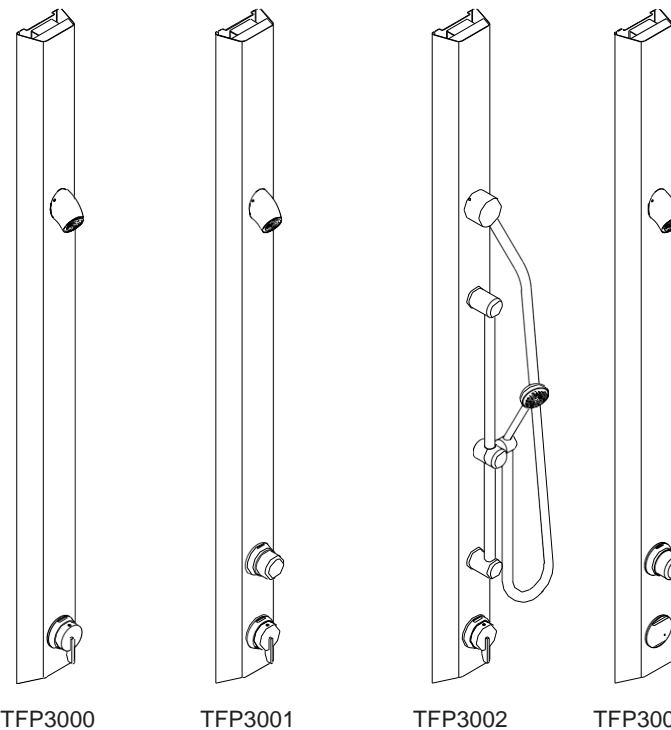

TFP3000

TFP3001

TFP3002

TFP3003

Bristan Group Ltd
Birch Coppice Business Park
Dordon
Tamworth
Staffordshire
B78 1SG
T: 0844 7016274
E: customer@bristan.com

Guarantee

This product is guaranteed against faulty materials and workmanship for 12 months from date of purchase. For the guarantee to be valid, the unit must be installed by a competent person, in accordance with the instruction booklet.

Any part found to be defective during the guarantee period, will (at our option) be repaired or replaced, free of charge, provided the unit has been installed, and properly used in accordance with the instruction booklet.

This guarantee does not affect your statutory rights.

Service Policy (Available in UK and ROI only)

In the event of a product or component fault, firstly follow the fault finding procedure to ensure the difficulty can be resolved.

If the fault can not be identified using the procedure, call the installer to check installation is correct.

Failing this, please contact the Customer Service Department on telephone number below.

Have following information prepared, to help identify the product:
Model type, Date of purchase, unit serial number (if available).

The Customer Service Department will attempt to diagnose the cause of the fault and advise the necessary action to resolve the problem over the phone.

If the fault can not be resolved and a service call is required, a Site Visit Request form will be sent to you to complete and return.

Where applicable a fixed fee payment for parts and/or labour will be levied. The cost incurred and payment methods will be advised over the phone and on the Site Visit Request form.

A completed form, along with payment (if applicable) must be received before the Service Callout can be arranged.

If the problem is not product related or is a component not of our manufacture, a fixed fee will be made to cover Site Visit costs. Additional costs for parts used to rectify the non-product related problem may be imposed.

During the visit, yourself or a responsible person should be present at all times. Charges will be made if the Service Engineer or Agent can not gain site access at the prearranged time.

Ensure water and/or electricity supplies have adequate isolation to the unit. If the unit is concealed, serviceable access should be provided. If servicing difficulties arise from not making the provisions detailed, additional time related costs or a recall charge will be imposed

Service Department
0844 701 6273

Agent:

The company reserve the right to alter product specifications without prior notice.

INTRODUCTION

It has been recognised that users of hot water in care establishments are at risk from scalding. This risk has been reduced by the use of thermostatic mixing valves. In order to assure the performance of thermostatic mixing valves N.H.S. Estates Model Engineering Specification DO8 was written. The valves listed in the following pages have been tested and approved to this standard by a third party as part of the BUILDCERT scheme for use within their designated applications.

The following abbreviated designation codes are used throughout this booklet. Detailed descriptions are given below:-

HP High pressure
 LP Low pressure
 S Shower
 B Bidet
 W Washbasin E Economy
 T44 Bath with fill temperature of 44°C max
 T46 Bath with fill temperature of 46°C max

THE TFP3000 SERIES OF SHOWER PANELS HAS BEEN APPROVED FOR USE IN THE FOLLOWING TMV3 DESIGNATIONS :-

LP-SE	LOW PRESSURE ECONOMY	
HP-SE	HIGH PRESSURE ECONOMY	

For full installation instructions and method of temperature adjustment see General Assembly and Servicing Guide.

INSTALLATION RECOMMENDATIONS

The following general recommendations should be observed.

- 1) The thermostatic mixing valve should be installed in such a position that maintenance and the commissioning and testing of the TMV can be undertaken.
- 2) Always flush both supply pipes fully before connecting mixing valve to ensure no pipe debris enters the inlets. Always fit filters provided.
- 3) All installations must comply with current local Water Company Regulations.

CONDITIONS FOR NORMAL USE

In order to give compliance with N.H.S. specification DO8 scheme. The tables below list the conditions for normal use, the valves may perform adequately outside these parameters but the TMV3 scheme approval does not apply. If they are required to work with other supply conditions an engineer must carry out a risk assessment and satisfy themselves that the units are still suitable for use.

Table 1: Conditions for normal use

Operating Pressure Range	Low Pressure	High Pressure
Maximum Static Pressure (bar)	10	10
Flow Pressure, Hot & Cold (bar)	0.2 to 1	1 to 5
Hot Supply Temperature (°C)	55 to 65	55 to 65
Cold Supply Temperature (°C)	5 to 20	5 to 20
Minimum temperature differential between mixed temperature and either supply	10°C	10°C

* It is NOT recommended that this product is used for installations below 0.5 bar

COMMISSIONING

Since the installed supply conditions may differ from those used in testing and setting the valves during final inspection and a valve may have several designations, it is necessary to reset the mix temperature. The following procedure should be used after ensuring:-

- a) The designation of the thermostatic mixing valve matches the intended application (i.e. if a shower is to be supplied at 2 bar then the valve must have a HP-S designation).
- b) The supply pressures match those for which the valve has been approved, see table1 and valve details.
- c) The supply temperatures are such that they are within the permitted range (see table1) and comply with guidance information on the prevention of legionella.

Note:- If the supply conditions are not within the parameters for normal use the valve may still be suitable, but individual engineers must carry out their own risk assessment and satisfy themselves that the units are still suitable for use. Adjust the mixed water temperature in accordance with table 2, the method of adjustment is covered in the section temperature Setting.

Servicing The Timed Flow Control Unit

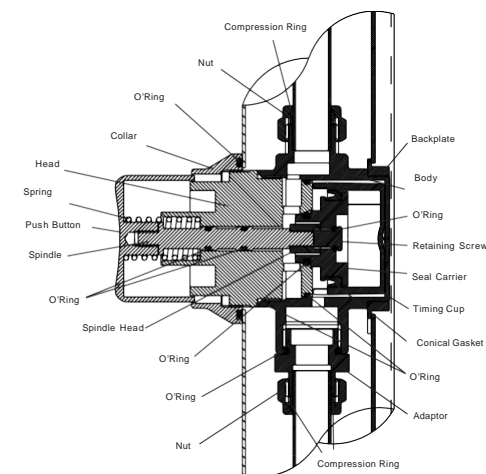

Removing the cartridge

After removing the Panel cover

- 1) Isolate both Hot and Cold water supplies.
- 2) To release the cartridge unscrew Head (1) using a 40mm A/F spanner
- 3) Remove Timing cup (2)
- 4) Unscrew Retaining screw (3) to gain access to all seals in the cartridge taking note of the correct orientation of the Spindle head (4).

Cleaning and lubrication

- 1) Soak all metal parts in descalent, wash off in clean water.
- 2) Examine all seals and replace if necessary.
- 3) Use a WRAS approved silicon based grease on all seals (light smear only). A maintenance kit is available, which contains all seals and grease from your local stockist or manufacturer.

Re-assembly

- 1) Re-assemble the cartridge as per the above diagram taking note that the Spindle head (4) and Conical gasket (5) are in the correct orientation and using a small amount of Loctite 222 on the thread of Retaining screw (3), secure cartridge with Retaining screw (3).

Note :- Do not use excessive amount of Loctite 222 when re-assembling the cartridge

- 2) Push Timing cup back into Body (6).
- 3) Screw the cartridge back into the Body (6) and fully tighten.
- 4) Refer to model number Installation procedures in this installation guide to complete the maintenance procedure.

Maximum Temperature Setting

IMPORTANT NOTE :- 1) PLEASE REFER TO MODEL NUMBER FOR CORRECT TEMPERATURE SETTING.

2) ALL INSTALLATION AND MAINTENANCE PROCEDURES SHOULD BE CARRIED OUT IN ACCORDANCE WITH THESE GUIDELINES. PLEASE READ THESE GUIDELINES BEFORE COMMENCING ANY NEW INSTALLATION OR SERVICING OF EXISTING UNITS.

3) EXTREME CARE IS REQUIRED WHEN SETTING THE TEMPERATURE OF THE OF THESE UNITS.

Model No.	Description
TFP3000	Adjustable temperature thermostatic control with fixed shower head
TFP3002	Adjustable temperature thermostatic control with flexible shower kit

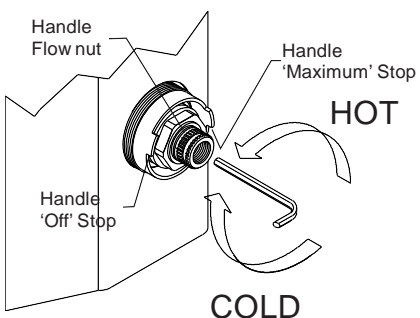

1. Use the handle to rotate the flow nut clockwise to turn off the thermostatic shower valve.
2. Place the handle fully on the flow nut with the stop in the handle against the 'Handle Off Stop' on the thermostatic shower valve. If fitted correctly, there will be minimum rotation clockwise. The handle will be allowed to rotate anti-clockwise until the handle stops rotating against the 'Handle Maximum Stop'.
3. With the handle now set fully open at the 'Handle Maximum Stop' position, remove the handle and insert the allen key into the temperature adjusting screw in the front of the flow nut and adjust the outlet temperature to 41°C. Turn the adjusting screw allen key clockwise for a cooler temperature, anti-clockwise for warmer temperature.
4. When temperature is set correctly, replace the handle with the handle stop against the 'Handle Maximum Stop'. Tighten the handle grub screw to fix the handle in place.
5. Rotate the handle clockwise until the handle stop engages with the thermostatic 'Handle Off Stop'. The valve should now be shut off with no flow of water through the Shower head or Handset.

Model No.	Description
TFP3001	Timed flow, adjustable temperature thermostatic control with fixed shower head

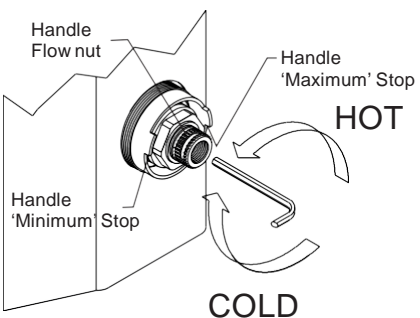

1. Use the handle to rotate the flow nut anti-clockwise until the thermostatic cartridge is fully open (The flow nut will no further rotate anti-clockwise).
2. Whilst depressing the Time flow push button insert the allen key into the temperature adjusting screw in the front of the flow nut and adjust the outlet temperature to 41°C. Turn the adjusting screw allen key clockwise for a cooler temperature, anti-clockwise for warmer temperature.
3. When temperature is set correctly, replace the handle with the handle stop against the 'Handle Maximum Stop'. Tighten the handle grub screw to fix the handle in place.
4. The handle is now set at its maximum temperature. The valve on/off controlled by the Timed flow device

Model No.	Description
TFP3003	Timed flow, fixed temperature thermostatic control with fixed shower head

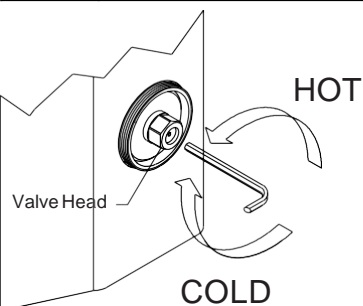

1. Whilst depressing the Time flow push button insert the allen key into the temperature adjusting screw in the front of the 'Valve Head' and adjust the outlet temperature to 41°C. Turn the adjusting screw allen key clockwise for a cooler temperature, anti-clockwise for warmer temperature.
2. When the temperature is set correctly, replace the thermostatic valve cover Plate.

Table 2: Mixed Water Temperature

Application	Abbreviated Designation	Mixed water temperature °C
Bidet	-HP-B, BE,-LP-B, BE	38 max
Shower	-HP-S,SE;-LP-S, SE	41 max
Washbasin	-HP-W,WE;-LP-W, WE	41 max
Bath (44°C fill)	-HP-T44;-LP-T44	44 max
Bath (46°C fill)	-HP-T46;-LP-T46	46 max

Note 1: For washbasins, washing under running water is assumed.

Note 2: Bath fill temperatures of more than 44°C should only be available when the bather is always under the supervision of a competent person (e.g. nurse or care assistant)

Note 3: A thermostatic mixing valve having multiple designations (i.e. it is capable of satisfying the requirements of this specification for more than one application) should be re-set on site to suit the designation required.

The following set of tests should be carried out.

- a) record the temperature of the hot and cold water supplies.
- b) record the temperature of the mixed water at the largest draw-off flow rate
- c) record the temperature of the mixed water at a smaller draw-off flow rate, which shall be measured.
- d) isolate the cold water supply to the mixing valve and monitor the mixed water temperature.
- e) record the maximum temperature achieved as a result of (d) and the final temperature.
- f) record the equipment, thermometer etc. used for the measurements.

IN-SERVICE TESTING

The purpose of in-service testing is to regularly monitor the thermal performance of the thermostatic mixing valve. Deterioration in performance can indicate the need for service work to be carried out on the system.

If the authority concerned does not have a planned test and maintenance schedule then the suggestions below should form the basis of a new system.

At intervals of 6 - 8 weeks and 12 - 15 weeks after commissioning:-

1. Check supply parameters are still within the expected values if not check system for faults.
2. Carry out commissioning procedures a) to c) using the same test equipment, if the mixed water temperature has changed a significant amount (by more than 1K) check to ensure in-line filters are clean, that the check valves are working and all isolating valves are fully open. If no fault can be found check and record the mixed water temperatures and re-adjust mixed water temperature to the values in table 2. Complete the commissioning procedure a) to f) if the mixed water temperature exceeds the values of the maximum recorded temperature by more than 2K the need for service work is indicated.

Depending on the results of these two tests the following should be adopted

- a) If a small change (e.g. 1K to 2K) occurs in one of these tests or there is no significant change (e.g. 1K maximum) then the next in service test should be 24 to 28 weeks after commissioning.
- b) If small changes occur in both test or a larger change occurs in one test (exceeding 2K) then the next in service test should be carried out 18 to 21 weeks after commissioning.

These results can then be used to set a service interval which tests have shown can be used with no more than a small change in mixed water temperature. This method of determining service intervals is used to take into account various in-service conditions (i.e. water condition) that the valve may experience.

NOTE: Valves operating outside these conditions cannot be guaranteed by the Scheme to operate as Type 3 valves.

Recommended outlet temperatures

The BuildCert TMV scheme recommends the following set maximum mixed water outlet temperatures for use in all premises:

44°C for bath fill but see notes below;

41°C for showers;

41°C for washbasins;

38°C for bidets.

The mixed water temperatures must never exceed 46°C.

The maximum mixed water temperature can be 2°C above the recommended maximum set outlet temperatures.

Note:

46°C is the maximum mixed water temperature from the bath tap. The maximum temperature takes account of the allowable temperature tolerances inherent in thermostatic mixing valves and temperature losses in metal baths.

It is not a safe bathing temperature for adults or children.

The British Burns Association recommends 37 to 37.5°C as a comfortable bathing temperature for children. In premises covered by the Care Standards Act 2000, the maximum mixed water outlet temperature is 43°C.

The fitting of isolation valves is required as close as is practicable to the water supply inlets of the thermostatic mixing valve.

The fitting of strainers is recommended as close as is practicable to the water supply inlets of the thermostatic mixing valve.

Commissioning notes for Thermostatic Mixing Valves.

The first step in commissioning a thermostatic mixing valve is to check the following:

The designation of the thermostatic mixing valve matches the application.

The supply pressures are within the valves operating range.

The supply temperatures are within the valves operating range.

Isolating valves (and strainers preferred) are provided.

If all these conditions are met, proceed to set the valve out temperature as stipulated in the manufacturer installation instructions.

The mixed water temperature at the terminal fitting must never exceed 46°C.

When commissioning/testing is due the following performance checks shall be carried out.

Measure the mixed water temperature at the outlet.

Carry out the cold water supply isolation test by isolating the cold water supply to the TMV, wait for five seconds if water is still flowing check that the temperature is below 46°C.

If there is no significant change to the set outlet temperature ($\pm 2^\circ\text{C}$ or less change from the original settings) and the fail-safe shut off is functioning, then the valve is working correctly and no further service work is required.

Notes

If there is a residual flow during the commissioning or the annual verification (cold water supply isolation test), then this is acceptable providing the temperature of the water seeping from the valve is no more than 2°C above the designated maximum mixed water outlet temperature setting of the valve.

Temperature readings should be taken at the normal flow rate after allowing for the system to stabilise.

The sensing part of the thermometer probe must be fully submerged in the water that is to be tested.

Any TMV that has been adjusted or serviced must be re-commissioned and re-tested in accordance with the manufacturers' instructions.

The installation of thermostatic mixing valves must comply with the requirements of the Water Supply (Water Fittings) Regulations 1999.

Specifications

Minimum pressure drop through fitting for mixing	0.5 bar
Maximum pressure drop through fitting for mixing	5 bar
Maximum static pressure to be applied to fitting	10 bar
Maximum pressure loss ratio	20:1 either supply
Temperature stability with normal variation of supply temperatures and pressures	$\pm 2^\circ\text{C}$ from set temperature
Factory standard blend temperature	43°C
Maximum hot supply temperature	80°C

The sensitive wax capsule will shut down the operation of the valve if either the hot or cold water supply fails, provided a minimum differential of 10°C exists between the mixed water temperature and the remaining supply.

NOTE:- If water pressure is above 3 Bar, a PRV (Pressure Reducing Valve) will need to be fitted

Removing , Cleaning and replacing the Thermostatic cartridge ,Thermostat and Piston Assembly

Model No.	Description
TFP3003	Timed flow, fixed temperature thermostatic control with fixed shower head

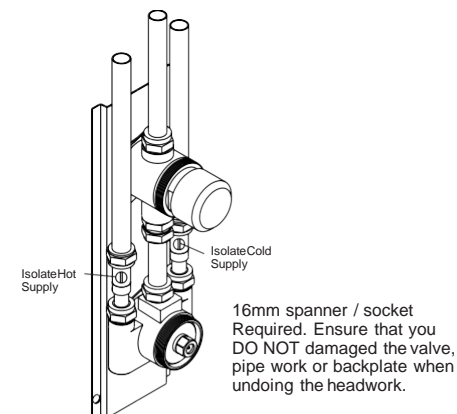

Removing the cartridge

- 1) Unscrew the cartridge (standard right hand thread).
- 2) Remove the thermostat, piston assembly and spring.
- 3) Remove all visible 'o' rings and washers from the body.

Cleaning and lubrication

- 1) Soak all metal parts in descalent, wash off in clean water.
- 2) Examine all seals and replace if necessary.
- 3) Use a WRAS approved silicon based grease on all seals (light smear only). A maintenance kit is available, which contains All seals and grease from your local stockist or manufacturer.

Removing the valve

If it is required to completely remove the Thermostatic mixing valve.

- 1) Isolate both Hot and Cold supplies.
- 2) Unscrew both Hot and Cold isolator swivel nuts at point of connection with the Thermostatic mixing valve.
- 3) Unscrew Thermostatic mixing valve outlet nut.
- 4) Remove two screws that fix the Thermostatic mixing valve to the stainless steel Wall plate.
- 5) Pull the Thermostatic mixing valve from Wall plate.

Do not remove the brass backplate from the base of the Thermostatic mixing valve

Re-assembly

- 1) Place the spring in the bottom of the piston assembly, then place the thermostat in the top.
- 2) Screw the cartridge back into the shower valve and fully tighten.
- 3) Refer to model number Installation and temperature setting procedures in this installation guide to complete the maintenance Procedure.

General fault diagnosis

If your thermostatic mixing valve fails to operate either immediately upon installation or after a period of time, the following points should be checked;

- 1) Check the hot & cold water feeds have been correctly fitted with hot on the left and cold on the right when viewed from the front.
- 2) Isolate supplies and ensure that both hot and cold supplies are reaching the valve body. You may need to dis-connect supply pipes to ensure this.
- 3) Ensure that there is no debris between the faces of the piston and it's mating faces, the bottom of the valve body and the Cartridge.
- 4) Check that the hot water temperature source is sufficient; preferred minimum of 60°C.

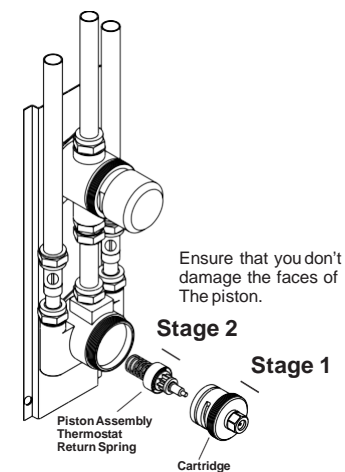
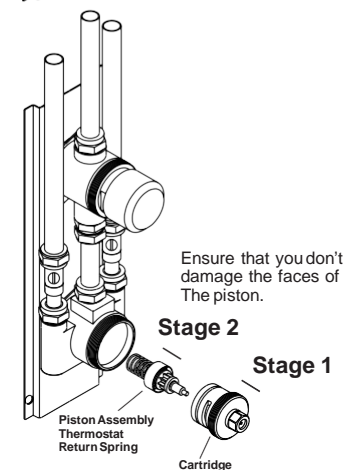

Removing , Cleaning and replacing the Thermostatic cartridge ,Thermostat and Piston Assembly

Model No.	Description
TFP3001	Timed flow, adjustable temperature thermostatic control with fixed shower head

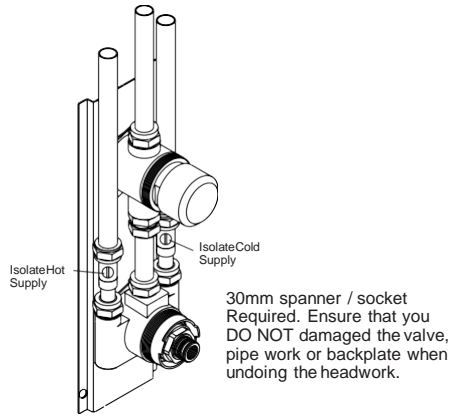

Removing the cartridge

- 1) Unscrew the cartridge (standard right hand thread).
- 2) Remove the thermostat, piston assembly and spring.
- 3) Remove all visible 'o' rings and washers from the body.

Cleaning and lubrication

- 1) Soak all metal parts in descalant, wash off in clean water.
- 2) Examine all seals and replace if necessary.
- 3) Use a WRAS approved silicon based grease on all seals (light smear only). A maintenance kit is available, which contains All seals and grease from your local stockist or manufacturer.

Removing the valve

If it is required to completely remove the Thermostatic mixing valve.

- 1) Isolate both Hot and Cold supplies.
- 2) Unscrew both Hot and Cold isolator swivel nuts at point of connection with the Thermostatic mixing valve.
- 3) Unscrew Thermostatic mixing valve outlet nut.
- 4) Remove two screws that fix the Thermostatic mixing valve to the stainless steel Wall plate.
- 5) Pull the Thermostatic mixing valve from Wall plate.

Do not remove the brass backplate from the base of the Thermostatic mixing valve

Re-assembly

- 1) Place the spring in the bottom of the piston assembly, then place the thermostat in the top.
- 2) Screw the cartridge back into the shower valve and fully tighten.
- 3) Refer to model number Installation and temperature setting procedures in this installation guide to complete the maintenance Procedure.

General fault diagnosis

If your thermostatic mixing valve fails to operate either immediately upon installation or after a period of time, the following points should be checked;

- 1) Check the hot & cold water feeds have been correctly fitted with hot on the left and cold on the right when viewed from the front.
- 2) Isolate supplies and ensure that both hot and cold supplies are reaching the valve body. You may need to dis-connect supply pipes to ensure this.
- 3) Ensure that there is no debris between the faces of the piston and it's mating faces, the bottom of the valve body and the Cartridge.
- 4) Check that the hot water temperature source is sufficient; preferred minimum of 60°C.

GENERAL DATA

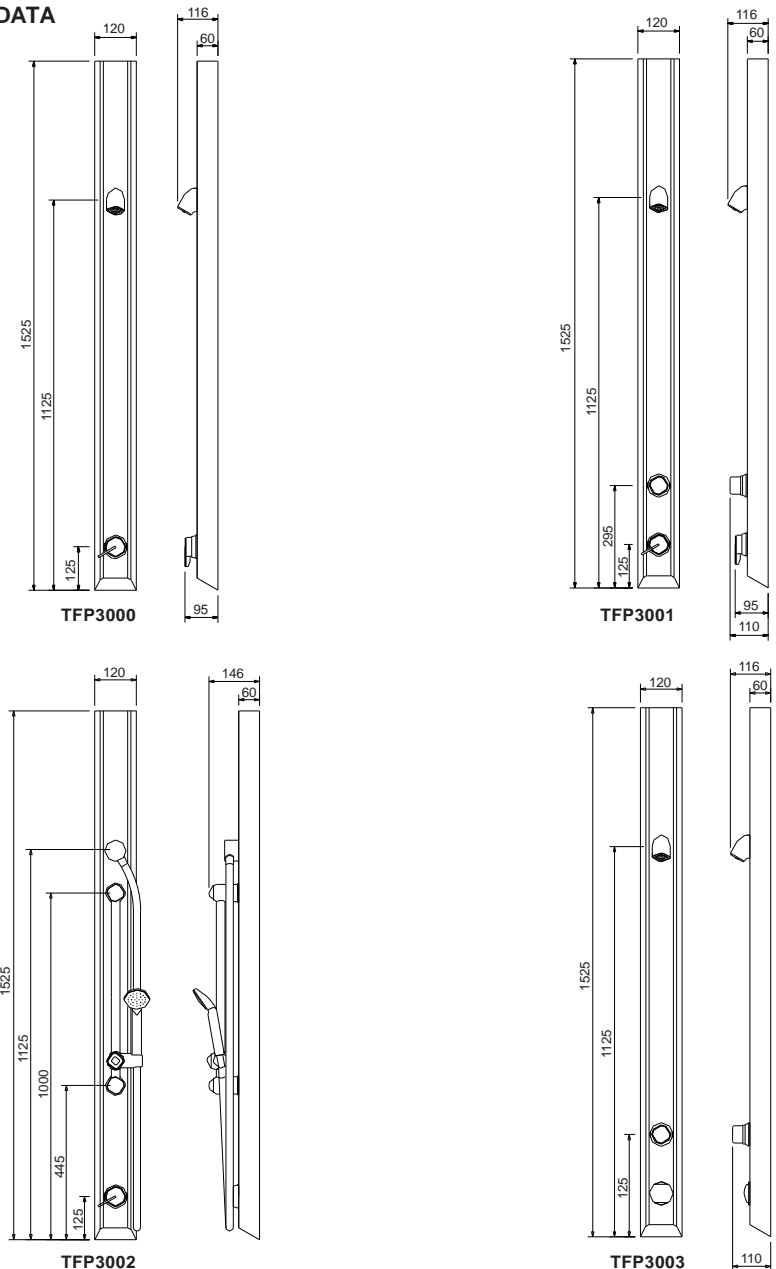

INLETS 15mm Compression

FLOW RATES

Pressure Drop (bar)	0.2*	0.5	0.6	0.8	1	2	3	4	5
Flow Rate (Litres/Min)	4.3*	6	6.6	7.4	8	8.2	8.4	8.6	8.5
Temperature °C	41*	41	41	41	41	41	41	41	41

Flow rates are open outlet with equal pressure drops, fitted with Non-return valves, Flow limiters and Filters as supplied.

* It is NOT recommended that this product is used for installations below 0.5 bar

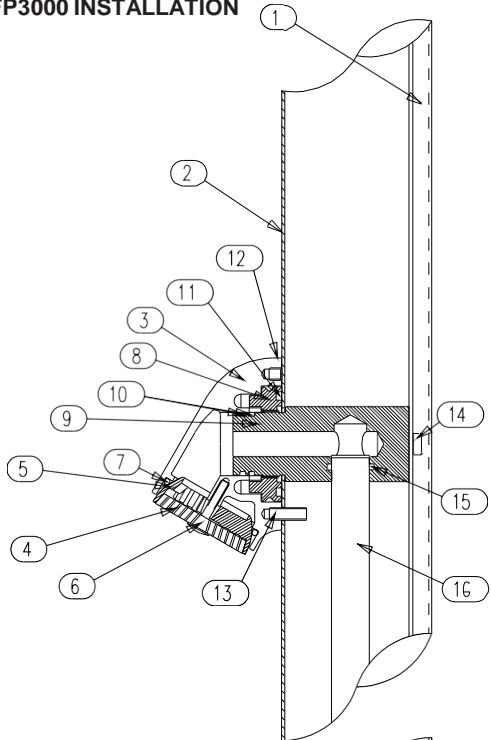

TFP 3000 PARTS		
NO	DESCRIPTION	NO OFF
1	STAINLESS STEEL WALL PLATE	1
2	STAINLESS STEEL FRONT PANEL	1
3	SHOWER HEAD	1
4	GREY 5 PART RING SEAL	1
5	GREY SWIVEL HOUSING	1
6	SPECIAL STAINLESS SCREW M3.5	1
7	BS128 O RING	1
8	WALL NUT	1
9	HEAD POST	1
10	BS 020 O RING	2
11	BS126 O RING	2
12	M5 x 5 CUP POINT SS GRUB SCREW	2
13	M5 x 12 CONE POINT SS GRUB SCREW	2
14	M5 x 10 PAN HEAD SS SCREW	4
15	BS113 O RING	1
16	15MM COPPER PIPE	1
17	THERMOSTATIC BODY	1
18	LEVER HANDLE	1
19	LAPPED PLASTIC PISTON	1
20	RETAINING COLLAR	1
21	DISTRIBUTOR	1
22	OVER TRAVEL SPRING	1
23	RETURN SPRING	1
24	THERMOSTAT ELEMENT	1
25	CARTRIDGE ASS-MB Y	1
26	41MM x 2MM O RING	1
27	15MM FILTER	2
28	CO-015 CHECK VALVE	2
29	10 FLOW IMIT-R	1
30	CLOW IMH-R	1
31	15MM STRAIGHT ISOLATION	2
32	VALVE SECURING COLLAR	1
33	BS 140 O RING	1
34	15MM COMPRESSION NUT	1
35	15MM COMPRESSION RING	1
36	BACK PLATE	1
37	M4x4 STAINLESS STEEL GRUB SCREW	2

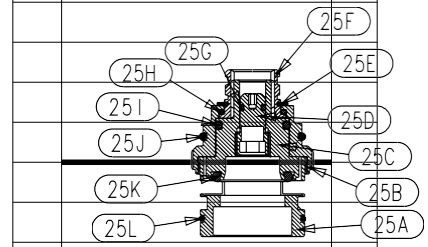
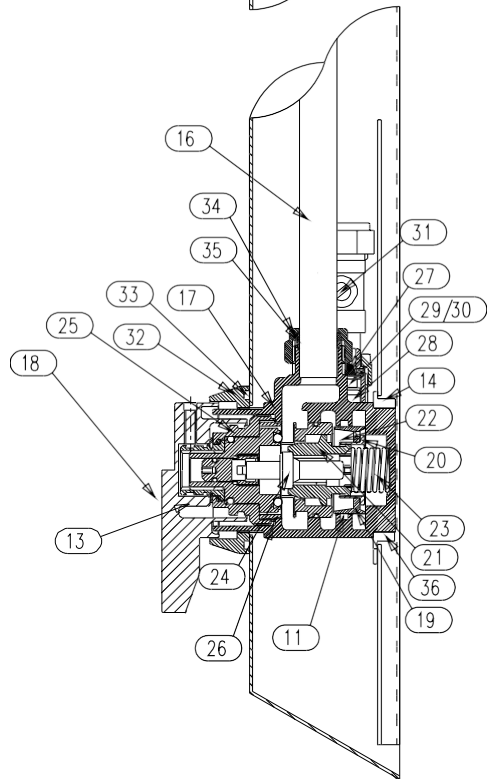

CARTRIDGE ASSEMBLY 971006 PARTS		
ITEM	DESCRIPTION	NO OFF
25A	HALF CARTRIDGE	1
25B	VALVE HEAD	1
25C	SHUT OFF HEAD	1
25D	ADJUSTING SCREW	1
25E	GRIP LIP	1
25F	FLOW NUT	1
25G	O RING BS010 EP70	1
25H	P.T.F.E. THRUST WASHER	1
25I	O RING BS118 70 SHORE NITRILE	1
25J	O RING BS123 NITRILE	1
25K	BS212 EP80 O RING	1
25L	O RING BS028 70 SHORE NITRILE	1

ModelNo.	Description
TFP3000	Adjustable temperature thermostatic control with fixed shower head
TFP3002	Adjustable temperature thermostatic control with flexible shower kit

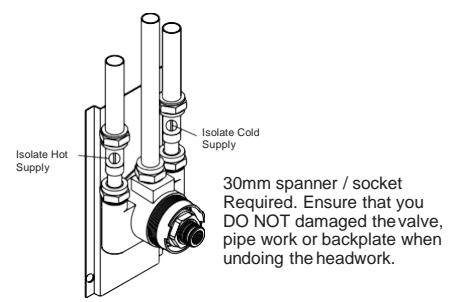

Removing the cartridge

- 1) Unscrew the cartridge (standard right hand thread).
- 2) Remove the thermostat, piston assembly and spring.
- 3) Remove all visible 'o' rings and washers from the body.

Cleaning and lubrication

- 1) Soak all metal parts in descalant, wash off in clean water.
- 2) Examine all seals and replace if necessary.
- 3) Use a WRAS approved silicon based grease on all seals (light smear only). A maintenance kit is available, which contains All seals and grease from your local stockist or manufacturer.

Removing the valve

If it is required to completely remove the Thermostatic mixing valve.

- 1) Isolate both Hot and Cold supplies.
- 2) Unscrew both Hot and Cold isolator swivel nuts at point of connection with the Thermostatic mixing valve.
- 3) Unscrew Thermostatic mixing valve outlet nut.
- 4) Remove two screws that fix the Thermostatic mixing valve to the stainless steel Wall plate.
- 5) Pull the Thermostatic mixing valve from Wall plate.

Do not remove the brass backplate from the base of the Thermostatic mixing valve

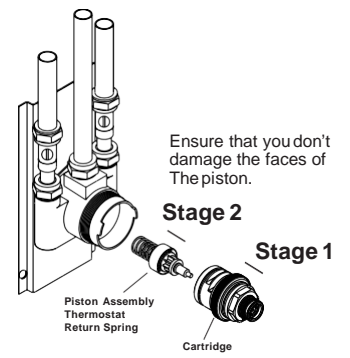

Re-assembly

- 1) Place the spring in the bottom of the piston assembly, then place the thermostat in the top.
- 2) Screw the cartridge back into the shower valve and fully tighten.
- 3) Refer to model number Installation and temperature setting procedures in this installation guide to complete the maintenance Procedure.

General fault diagnosis

If your thermostatic mixing valve fails to operate either immediately upon installation or after a period of time, the following points should be checked;

- 1) Check the hot & cold water feeds have been correctly fitted with hot on the left and cold on the right when viewed from the front.
- 2) Isolate supplies and ensure that both hot and cold supplies are reaching the valve body. You may need to dis-connect supply pipes to ensure this.
- 3) Ensure that there is no debris between the faces of the piston and it's mating faces, the bottom of the valve body and the Cartridge.
- 4) Check that the hot water temperature source is sufficient; preferred minimum of 60°C.

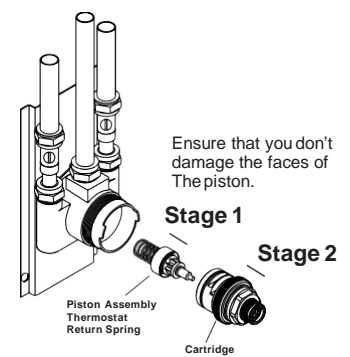

If your thermostatic mixing valve fails to operate it could be the result of incorrect installation. Please refer to installation and site requirements.

If the valve has operated correctly for a time, but no longer performs acceptably, it may require servicing/cleaning. Proceed as follows;

To remove the Panel front cover

For model :- TFP3000 (page 6-7)

- 1) Ensure thermostatic mixing valve is turned off and no water flow through outlet showerhead.
- 2) Loosen Handle grub screw and remove Handle (18) from Thermostatic valve.
- 3) Unscrew Collar (32).
- 4) Loosed both Grubscrews (12) in the shower head and pull showerhead off Head post (9).
- 5) Whilst holding the panel cover Remove Wall nut (8).
- 6) Slide panel forward and remove, thus exposing pipework and fittings.
- 7) Isolate Hot and Cold water supplies,

For model :- TFP3001 (page 8-9)

- 1) Loosen Handle grub screw and remove Handle (19) from Thermostatic valve.
- 2) Unscrew Collar (33).
- 3) Unscrew Collar (38).
- 4) Loosed both Grubscrews (12) in the shower head and pull showerhead off Head post (9).
- 5) Whilst holding the panel cover Remove Wall nut (8).
- 6) Slide panel forward and remove, thus exposing pipework and fittings.
- 7) Isolate Hot and Cold water supplies,

For model :- TFP3002 (page 10-11)

- 1) Ensure thermostatic mixing valve is turned off and no water flow through outlet showerhead.
- 2) Loosen Handle grub screw and remove Handle (21) from Thermostatic valve.
- 3) Unscrew Collar (35).
- 4) Loosed both Grubscrews (15) in the Head cover and pull Hose connector(3) off Head post (12).
- 5) Whilst holding the panel cover Remove Wall nut (11).
- 6) Slide panel forward and remove, thus exposing pipework and fittings.
- 7) Isolate Hot and Cold water supplies,

For model :- TFP3001 (page 12-13)

- 1) Unscrew Fixed cover (34) from Thermostatic valve.
- 2) Unscrew Collar (39).
- 3) Loosed both Grubscrews (12) in the shower head and pull showerhead off Head post (9).
- 4) Whilst holding the panel cover Remove Wall nut (8).
- 5) Slide panel forward and remove, thus exposing pipework and fittings.
- 6) Isolate Hot and Cold water supplies.

NON-RETURN VALVES , FLOW LIMITERS AND FILTER DETAILS FOR ALL MODEL VARIANTS

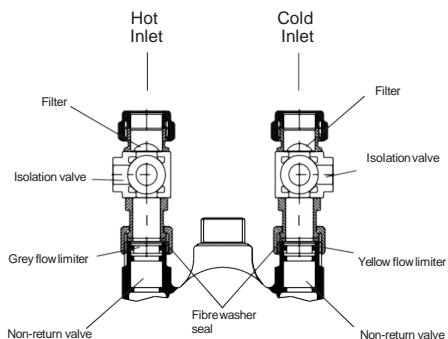

Valve inlet details as viewed from the Front of the panel when installed

Note :-

1. Isolation valves are supplied fitted as standard to the thermostatic mixing valve and take 15mm copper tube.
2. Non-return valves, flow limiters and filters are fitted as standard and should not be removed for any reason other than maintenance purposes.
3. If you are removing the Non-return valves , Filters , Flow limiters for maintenance purposes please ensure they are re-installed in the correct Hot / Cold inlet port and orientation for the direction of water flow as detailed above. Failure to do so will result in the Panel operating incorrectly.

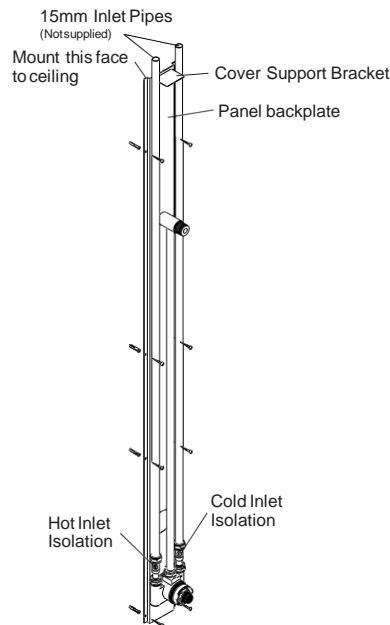

- 1) Decide the appropriate place to mount the Shower panel.
- 2) Place panel backplate on the wall and up against the ceiling and mark fixing hole locations.
- 3) Drill and Plug holes to suite.
- 4) Secure panel backplate to wall with plugs and screws provided.
- 5) Connect inlet pipes to Hot and Cold isolators ensuring filters supplied are fitted.

NOTE :- Hot inlet on the left and Cold inlet on the right as viewed from the front of the installation

If water pressure is above 3 Bar, a PRV (Pressure Reducing Valve) will need to be fitted

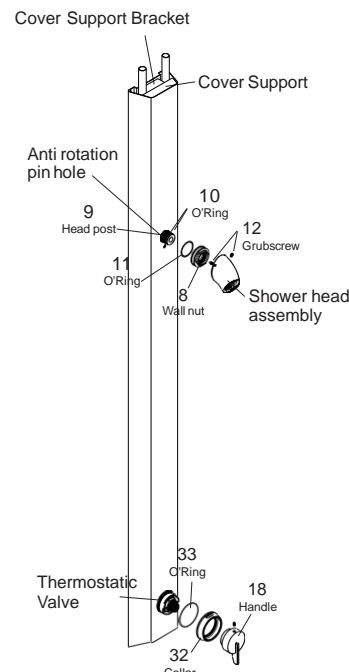

- 1) Place Cover onto Panel backplate ensuring the Cover support is placed on top of the Cover support bracket.
- 2) Ensuring O'ring (11) is fitted into the Wall nut (8) and O'rings (10) are fitted onto Head post (9), Secure Wall nut (8) onto Head post (9).
- 3) Push Shower head assembly onto Head post (9) ensuring the anti-rotation pin on the back of the Shower head assembly is located in the Anti-rotation pin hole on the cover and secure with grub screws (12).
- 4) Ensuring O'Ring (33) is fitted into Valve securing collar (32) , Screw securing collar (32) onto Thermostatic valve and tighten.

Note :- To fit the handle (18) , please refer to Temperature setting on page 18

TFP3001 INSTALLATION

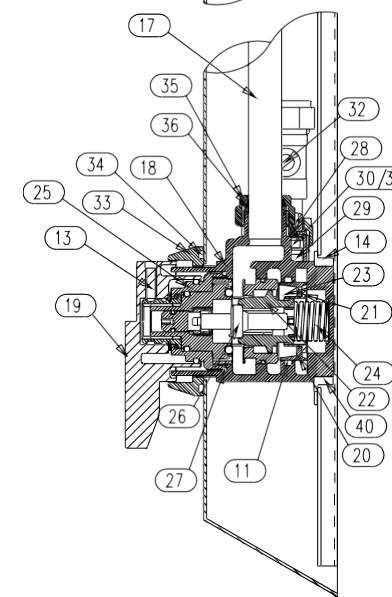
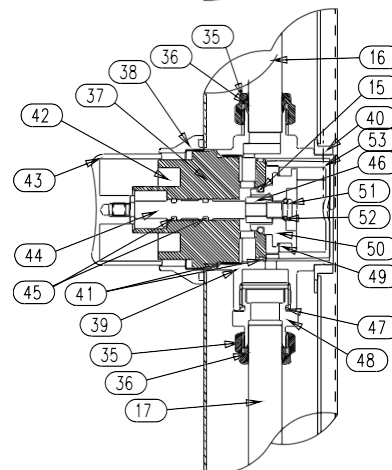
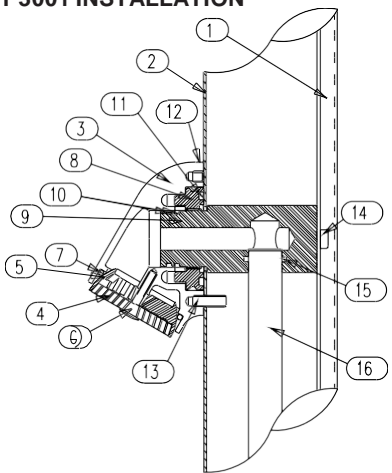

TFP3003 PARTS

ITEM NO	DESCRIPTION	NO OFF
1	STAINLESS STEEL WALL PLATE	1
2	STAINLESS STEEL FRONT PANEL	1
3	SHOWER HEAD	1
4	GREY 5 PART RING SET	1
5	GREY SWIVEL HOUSING	1
6	SPECIAL STAINLESS SCREW M3.5	1
7	BS128 O RING	1
8	WALL NUT	1
9	HEAD POST	1
10	BS 020 O RING	2
11	BS126 O RING	2
12	M5 * 5 CUP POINT SS GRUB SCREW	2
13	M5 * 12 CONE POINT SS GRUB SCREW	2
14	M5 * 10 PAN HEAD SS SCREW	6
15	BS113 O RING	2
16	15MM COPPER PIPE	1
17	15MM COPPER PIPE	1
18	THERMOSTATIC BODY	1
19	LEVER HANDLE	1
20	LAPPED PLASTIC PISTON	1
21	RETAINING COLLAR	1
22	DISTRIBUTOR	1
23	OVER TRAVEL SPRING	1
24	RETURN SPRING	1
25	CARTRIDGE ASSEMBLY	1
26	THERMOSTAT ELEMENT	1
27	41MM * 2MM O RING	1
28	15MM FILTER	2
29	CO 015 CHECK VALVE	2
30	10L FLOW LIMITER	1
31	6L FLOW LIMITER	1
32	15MM STRAIGHT ISOLATION	2
33	VALVE SECURING COLLAR	1
34	BS 140 O RING	2
35	15MM COMPRESSION NUT	3
36	15MM COMPRESSION RING	3
37	TIME FLOW CONTROL HEAD	1
38	TIME FLOW SECURING COLLAR	1
39	TIME FLOW BODY	1
40	BACK PLATE	2
41	BS030 O RING	2
42	RETURN SPRING	1
43	PUSH BUTTON	1
44	SPINDLE	1
45	BS010 O RING	2
46	SPINDLE HEAD	1
47	BS 017 O RING	1
48	ADAPTOR	1
49	CONICAL GASKET	1
50	SEAL CARRIER	1
51	RETAINING SCREW	1
52	BS 009 O RING	1
53	TIMING CUP	1
55	M4 GRUB SCREW	4

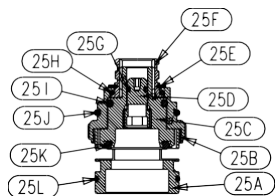

CARTRIDGE ASSEMBLY 971006 PARTS		
ITEM	DESCRIPTION	NO OFF
25A	HALF CARTRIDGE	1
25B	VALVE HEAD	1
25C	SHUT OFF HEAD	1
25D	ADJUSTING SCREW	1
25E	CIRCLIP	1
25F	FLOW NUT	1
25G	O RING BS010 EP70	1
25H	P.T.F.E. THRUST WASHER	1
25I	O RING BS118 70 SHORE NITRILE	1
25J	O RING BS123 NITRILE	1
25K	BS212 EP80 O RING	1
25L	O RING BS028 70 SHORE NITRILE	1

TFP3003 INSTALLATION

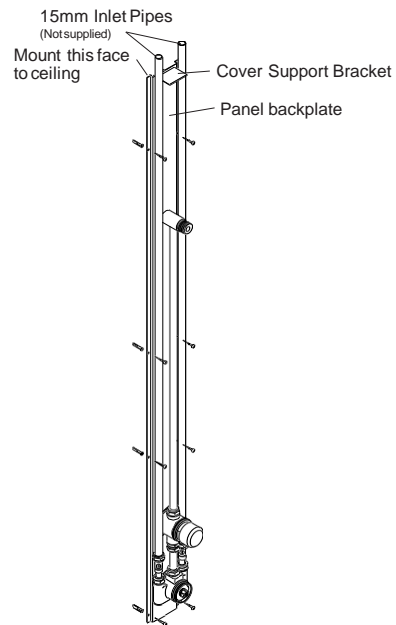

- 1) Decide the appropriate place to mount the Shower panel.
- 2) Place panel backplate on the wall and up against the ceiling and mark fixing hole locations.
- 3) Drill and Plug holes to suite.
- 4) Secure panel backplate to wall with plugs and screws provided.
- 5) Connect inlet pipes to Hot and Cold isolators ensuring filters supplied are fitted.

NOTE :- Hot inlet on the left and Cold inlet on the right as viewed from the front of the installation

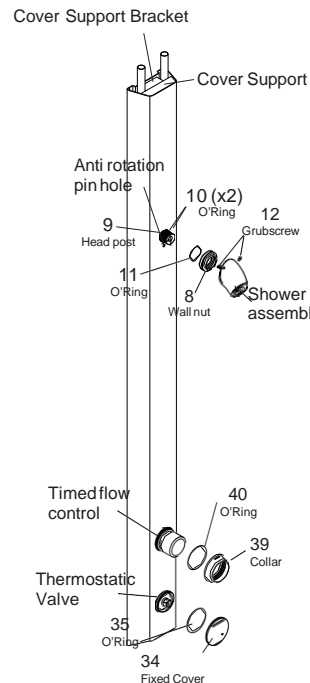

- 1) Place Cover onto Panel backplate ensuring the Cover support is placed on top of the Cover support bracket.
- 2) Ensuring O'ring (11) is fitted into the Wall nut (8) and O'rings (10) are fitted onto Head post (9), Secure Wall nut (8) onto Head post (9).
- 3) Push Shower head assembly onto Head post (9) ensuring the anti-rotation pin on the back of the Shower head assembly is located in the Anti-rotation pin hole on the cover and secure with grubscrews (12).
- 4) Ensuring O'Ring (40) is fitted into Timed flow securing collar (39), Screw securing collar (39) onto Timed flow valve and tighten.

Note :- Before fitting Fixed cover (34) , please refer to temperature setting on page 18

- 5) After temperature is set ,ensure O'Ring (35) is fitted into fixed cover (34), Screw Fixed cover (34) onto thermostatic valve and tighten.

TFP3003 INSTALLATION

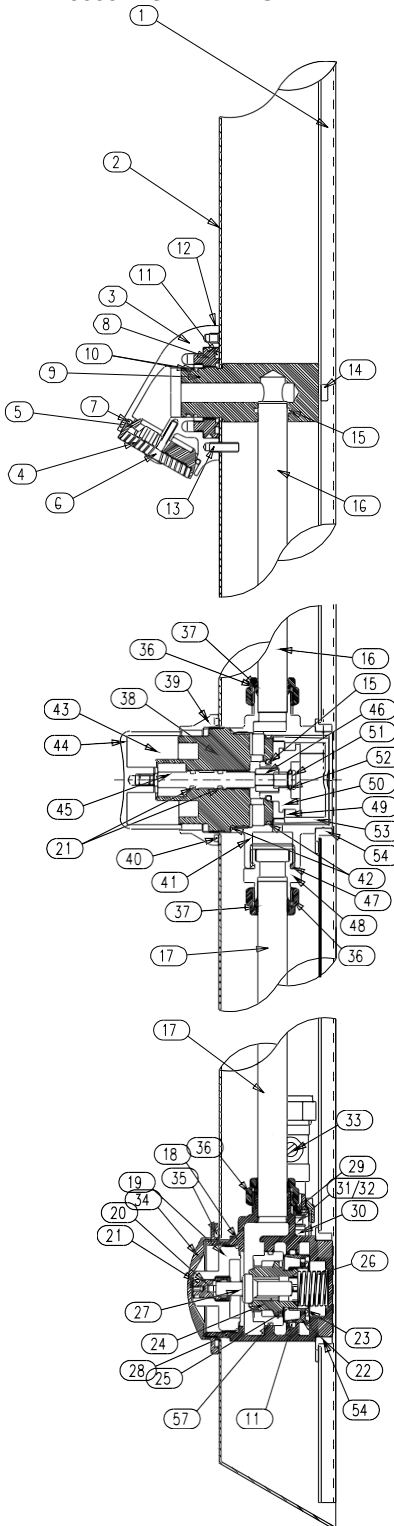

TFP 3003 PARTS		
ITEM NO	DESCRIPTION	NO OFF
1	STAINLESS STEEL WALL PLATE	1
2	STAINLESS STEEL FRONT PANEL	1
3	SHOWER HEAD	1
4	GREY 5 PART RING SET	1
5	GREY SWIVEL HOUSING	1
6	SPECIAL STAINLESS SCREW M3.5	1
7	BS128 O RING	1
8	WALL NUT	1
9	HEAD POST	1
10	BS 020 O RING	2
11	BS126 O RING	2
12	M5 * 5 CUP POINT SS GRUB SCREW	2
13	M5 * 12 CONE POINT SS GRUB SCREW	2
14	M5 * 10 PAN HEAD SS SCREW	6
15	BS113 O RING	2
16	15MM COPPER PIPE	1
17	15MM COPPER PIPE	1
18	THERMOSTATIC BODY	1
19	FIXED TEMPERATURE HEAD	1
20	TEMPERATURE ADJUSTING SCREW	1
21	BS010 O RING 90 SHORE	3
22	LAPPED PLASTIC PISTON	1
23	PLASTIC RETAINING COLLAR	1
24	PLASTIC DISTRIBUTOR	1
25	STAINLESS STEEL OVERTRAVEL SPRING	1
26	STAINLESS STEEL RETURN SPRING	1
27	THERMOSTAT ELEMENT	1
28	41MM*2MM O RING	1
29	15MM FILTER	2
30	CO 015 PLASTIC CHECK VALVE	2
31	10L FLOW LIMITER	1
32	6L FLOW LIMITER	1
33	15MM STRAIGHT ISOLATION	2
34	ETCHED FIXED TEMPERATURE COVER	1
35	BS137 O RING	1
36	15MM COMPRESSION NUT	3
37	15MM COMPRESSION RING	3
38	TIME FLOW CONTROL HEAD	1
39	TIME FLOW SECURING COLLAR	1
40	BS 140 O RING	1
41	TIME FLOW BODY	1
42	BS 030 O RING	2
43	RETURN SPRING	1
44	ETCHED PUSH BUTTON	1
45	SPINDLE	1
46	SPINDLE HEAD	1
47	BS 0170 RING	1
48	ADAPTOR	1
49	CONICAL GASKET	1
50	SEAL CARRIER	1
51	RETAINING SCREW	1
52	BS 009 O RING	1
53	TIMING CUP	1
54	BACKPLATE	2
55	BS028 O RING	1
56	M4 GRUB SCREW	4

TFP3003 INSTALLATION

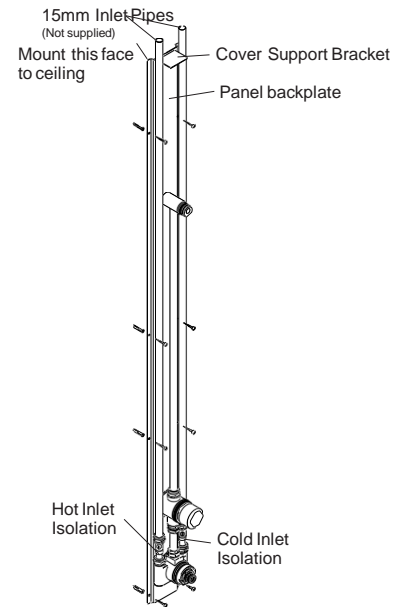

- 1) Decide the appropriate place to mount the Shower panel.
- 2) Place panel backplate on the wall and up against the ceiling and mark fixing hole locations.
- 3) Drill and Plug holes to suite.
- 4) Secure panel backplate to wall with plugs and screws provided.
- 5) Connect inlet pipes to Hot and Cold isolators ensuring filters supplied are fitted.

NOTE :- Hot inlet on the left and Cold inlet on the right as viewed from the front of the installation

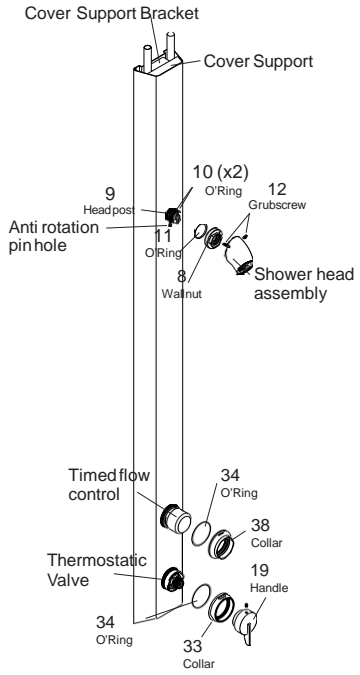

- 1) Place Cover onto Panel backplate ensuring the Cover support is placed on top of the Cover support bracket.
- 2) Ensuring O'ring (11) is fitted into the Wall nut (8) and O'rings (10) are fitted onto Head post (9), Secure Wall nut (8) onto Head post (9).
- 3) Push Shower head assembly onto Head post (9) ensuring the anti-rotation pin on the back of the Shower head assembly is located in the Anti-rotation pin hole on the cover and secure with grubscrews (12).
- 4) Ensuring O'Ring (34) is fitted into Timed flow securing collar (38), Screw securing collar (38) onto Timed flow valve and tighten.
- 5) Ensuring O'Ring (34) is fitted into Valve securing collar (33), Screw securing collar (33) onto Thermostatic valve and tighten.

Note :- To fit the handle (19), please refer to Temperature setting on page 18

TFP3002 INSTALLATION

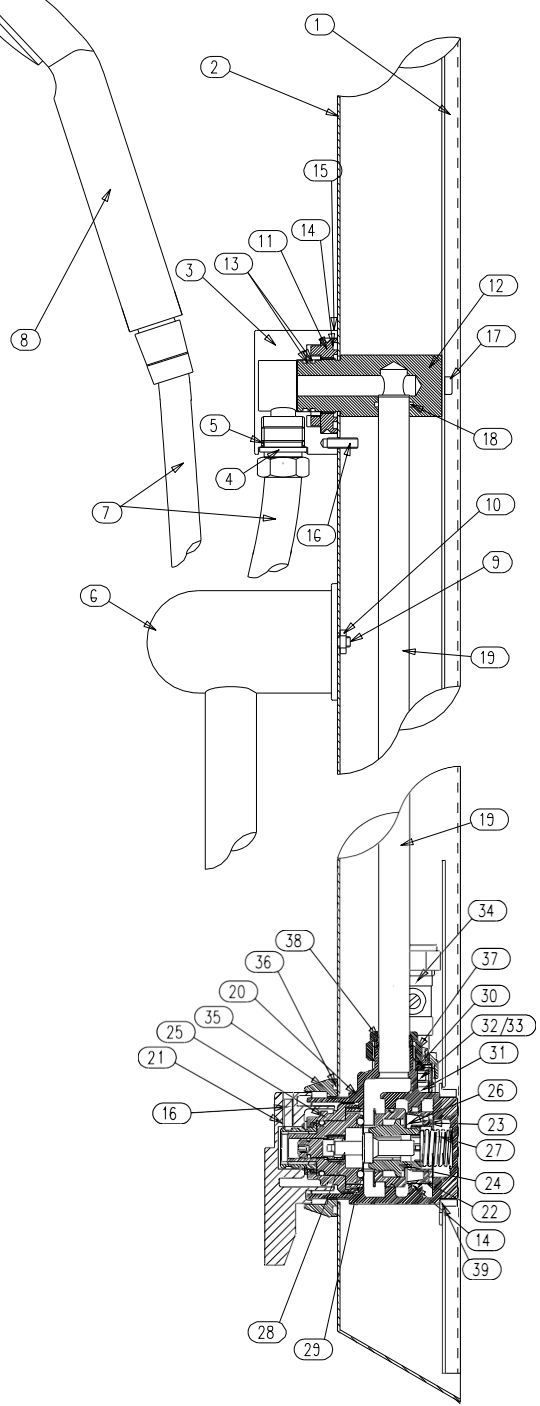

TFP3002 PARTS		
ITEM NO	DESCRIPTION	NO OFF
1	STAINLESS STEEL WALL PLATE	1
2	STAINLESS STEEL FRONT PANEL	1
3	PANEL HOSE CONNECTION	1
4	HOSE CONNECTOR	1
5	BS017 O RING	1
6	SHOWER SLIDE BAR KIT	1
7	HOSE	1
8	HANDSET	1
9	M4 S.S. CAP HEAD SCREW	2
10	M4 S.S. NUT	2
11	WALL NUT	1
12	HEAD POST	1
13	BS 020 O RING	2
14	BS126 O RING	2
15	M5 * 6 GRUB SCREW STAINLESS STEEL	2
16	M5 * 12 GRUB SCREW STAINLESS STEEL	2
17	M5 * 10 LNG STAINLESS SCREWS PAN HEAD	4
18	BS 113 O RING	1
19	15MM COPPER PIPE	1
20	THERMOSTATIC BODY	1
21	LEVER HANDLE	1
22	LAPPED PLASTIC PISTON	1
23	RETAINING COLLAR	1
24	PLASTIC DISTRIBUTOR	1
25	CARTRIDGE ASSEMBLY	1
26	OVER TRAVEL SPRING	1
27	RETURN SPRING	1
28	THERMOSTAT ELEMENT	1
29	41MM ID *2MM O RING	1
30	15MM FILTER	2
31	CO 015 CHECK VALVE	2
32	10L FLOW LIMITER	1
33	6L FLOW LIMITER	1
34	15MM STRAIGHT ISOLATION	2
35	VALVE SECURING COLLAR	1
36	BS 140 O RING	1
37	15MM COMPRESSION NUT	1
38	15MM COMPRESSION RING	1
39	BACKPLATE	1
40	M4 GRUB SCREW	2

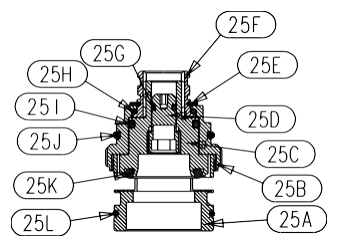

ITEM 25 VALVE CARTRIDGE ASSEMBLY 971006 PARTS		
ITEM	DESCRIPTION	NO OFF
25A	HALF CARTRIDGE	1
25B	VALVE HEAD	1
25C	SHUT OFF HEAD	1
25D	ADJUSTING SCREW	1
25E	CIRCLIP	1
25F	FLOW NUT	1
25G	O RING BS010 EP70	1
25H	P.T.F.E. THRUST WASHER	1
25I	O RING BS118 70 SHORE NITRILE	1
25J	O RING BS123 NITRILE	1
25K	BS212 EP80 O RING	1
25L	O RING BS028 70 SHORE NITRILE	1

TFP3002 INSTALLATION

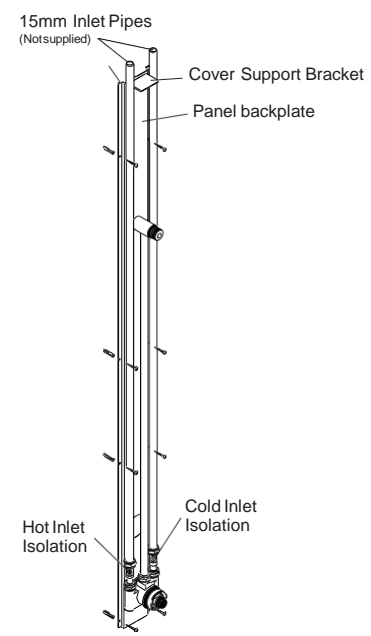

- 1) Decide the appropriate place to mount the Shower panel.
- 2) Place panel backplate on the wall and up against the ceiling and mark fixing hole locations.
- 3) Drill and Plug holes to suite.
- 4) Secure panel backplate to wall with plugs and screws provided.
- 5) Connect inlet pipes to Hot and Cold isolators ensuring filters supplied are fitted.

NOTE :- Hot inlet on the left and Cold inlet on the right as viewed from the front of the installation

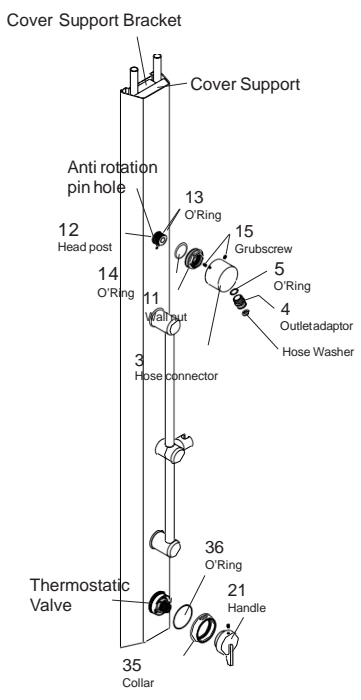

- 1) Place Cover onto Panel backplate ensuring the Cover support is placed on top of the Cover support bracket.
- 2) Ensuring O'ring (14) is fitted into the Wall nut (11) and O'rings (13) are fitted onto Head post (12), Secure Wall nut (11) onto Head post (12).
- 3) Push Hose connector assembly onto Head post (12) ensuring the anti-rotation pin on the back of the Hose connector assembly is located in the Anti-rotation pin hole on the cover and secure with grubscrews (15).
- 4) Ensuring O'Ring (36) is fitted into Valve securing collar (35), Screw securing collar (35) onto Thermostatic valve and tighten.
- 5) Connect hose to Hose connector(3) ensuring the hose washer is used to create a water tight seal.
- 6) Connect handset to hose ensuring the hose washer is used to create a water tight seal.

Note :- To fit the handle (21), please refer to temperature setting on page 18