

BASIN INSTALLATION

- Apply a layer of silicone sealant (not provided) both to the underside of the worktop and the topside of the rim of the basin as shown.
- Carefully align basin in place so that there is an even worktop overhang on all edges. The basin overflow should be at the FRONT of the basin / worktop
- Fix the undermount brackets to the worktop using the bolts supplied. This will further secure the basin in place. Allow sealant to fully set before proceeding.
- Once the silicone sealant is dry, wipe away all excess sealant.
- Worktop should be sealed to furniture using silicone sealant
- All plumbing connections to the basin / worktop should be tested for leaks once installation is complete

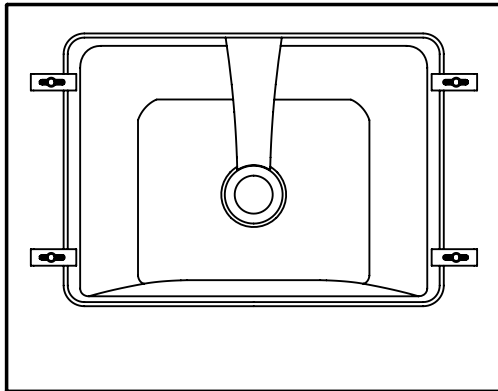

Note: Worktops are supplied undrilled.
Follow separate instructions for tap hole cutting

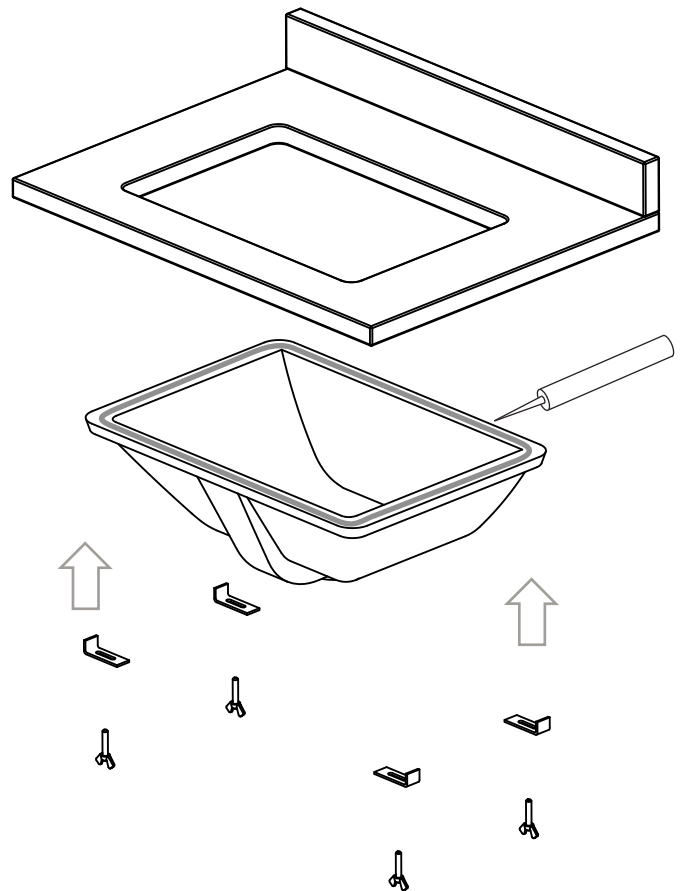

AFTERCARE INSTRUCTIONS

- Your Strata surface should be cleaned with a damp cloth and then buffed with a dry cloth.
- Any residue and spills from, shampoo, toothpaste, mouthwash etc, should be cleaned immediately with soapy water to ensure no staining occurs

DO NOT

- Use any abrasive agents, aggressive detergents or vinegar.
- Expose Strata surface to strong chemicals such as nail varnish remover, paint removers etc. These should be removed immediately.
- Slide hard/sharp objects (cups, bottles etc) across the surface as these will result in scratches.

REPAIRING WORKTOPS

If your strata worktop does become scratched it is possible to repair this using the below method:

- Sand the affected area working up through the paper grit as below:
 1. Start the sanding process with a 150 grit paper
 2. 220 grit
 3. 320 grit
 4. 500 / 800 grit soft finishing pad
- Polish using t-cut (or other similar polishing products) with a clean dry cloth
- Finish using 'countertop magic' or similar proprietary products.

REPLACEMENT PARTS

Should you require any replacement components for this product please contact Roper Rhodes using the contact details below.